

INDIA

MULTITECH SYSTEMS

Plot No. 48-49, Gali No.6, Krishna Colony, Opp. Sector-25, Faridabad-121004, Haryana
Mob.: 9911417747, 9560063747, 9910705767, 9911723747, 9910043747, 9911283747

E-mail : mtscranes@gmail.com | sales@multitechsystems.in

www.multitechsystem.net

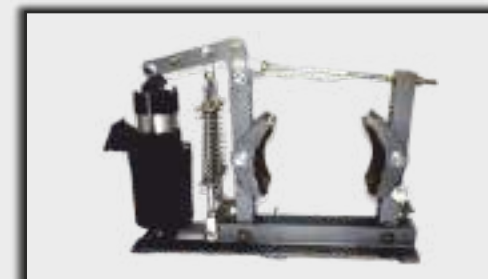
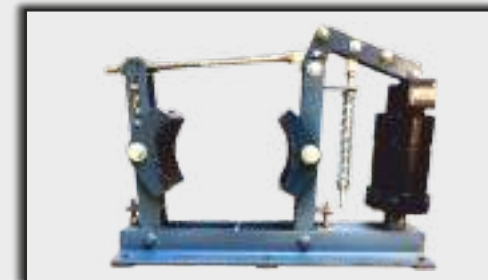

Compact Shrouded Conductor System

MTS - 1

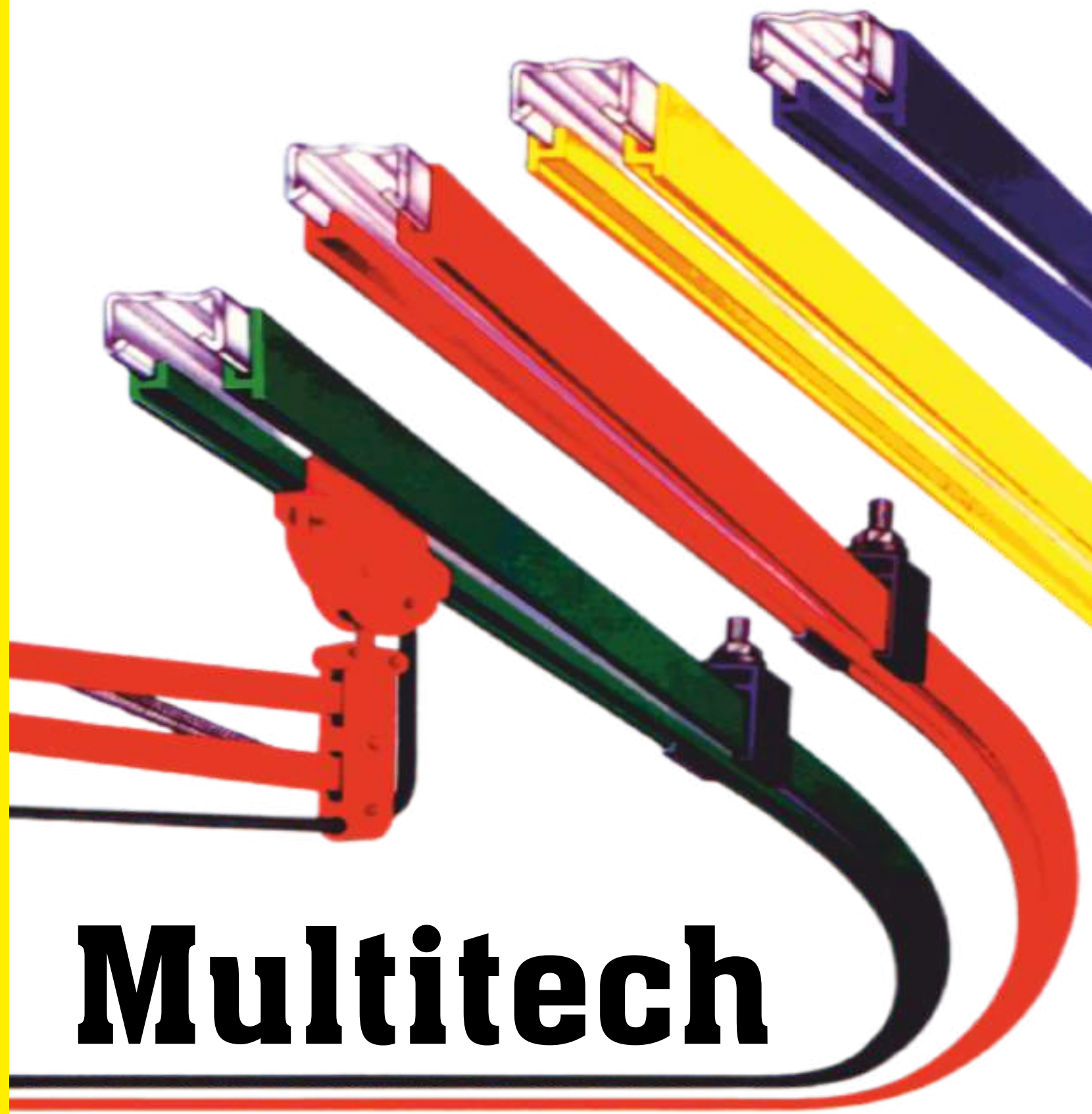

Multitech

Compact Shrouded Conductor System

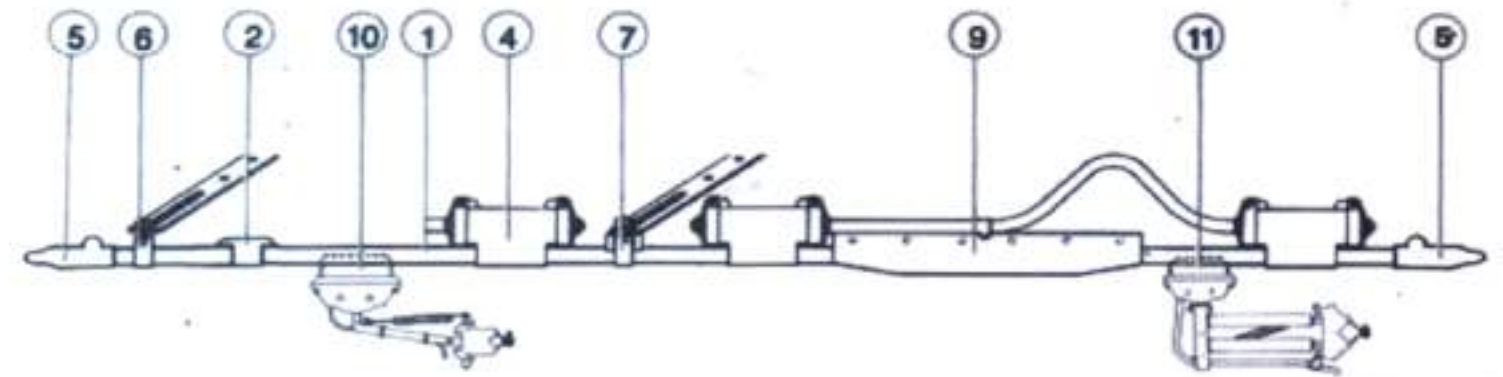

1. Bar, covered and Pin Assembly - 4M Long 125 100A rolled G.I. Conductor assembly 250A-Rolled CU-Conductor assembly. 40A-Rolled S.S Conductor assembly. Max. Working temp.80°C

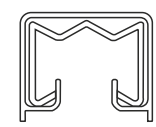

No.101.

2. Splice Cover Moulded Plastic one piece clip on cover



No.102

3. Crimping Tool For copper conductors only.



No.103

4. Centre Power feed kit Kit comprising power feed clamp fixing nuts and bolts and insulating cover.

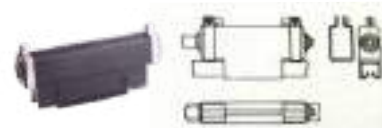

No.104

5. End cap Kit comprising stop bolt and PVC push-on insulating cover.



No.105

6. Hanger clamp Plastic moulded snap-on type suport.



No.106

Collector and conductor support brackets are available

7. Anchor clamp Plastic moulded snap-on type with self anchoring feature for use at anchor points.



No.107

8. Jointing tool Special assembly tool required to connect barson site.



No.108

9. Expansion Assembly Complete factory assembled unit of 2 meters over all lenth



No.109

10. 125A Type collector SS For use with hoist applications. Straight runs only.



No.110

COLLECTOR MOVENT
VERTICAL : 45mm
LATERAL : 35mm

11. 125A D type collector For use on straight/ curved systems.



No.111

COLLECTOR MOVENT
VERTICAL : 60mm
LATERAL : 50mm

Technical data:
Conductor Spacing : Indoor 30mm min. / Outdoor 40mm min.
For working temperatures exceeding 800 C consult our technical departmant
NOTE : Tandem collectors are required when expansion sections are fitted.



Multitech Systems

Plot No. 48-49, Gali No.6, Krishna Colony, Opp. Sector-25, Faridabad-121004, Haryana
E-mail : mtscranes@gmail.com | sales@multitechsystems.in
www.multitechsystem.net, 9910705767, 9911723747



9911417747
9560063747
9910043747
9911283747



Multitech Systems

Plot No. 48-49, Gali No.6, Krishna Colony, Opp. Sector-25, Faridabad-121004, Haryana
E-mail : mtscranes@gmail.com | sales@multitechsystems.in
www.multitechsystem.net, 9910705767, 9911723747



9911417747
9560063747
9910043747
9911283747

Compact Shrouded Conductor System

MTS - 2

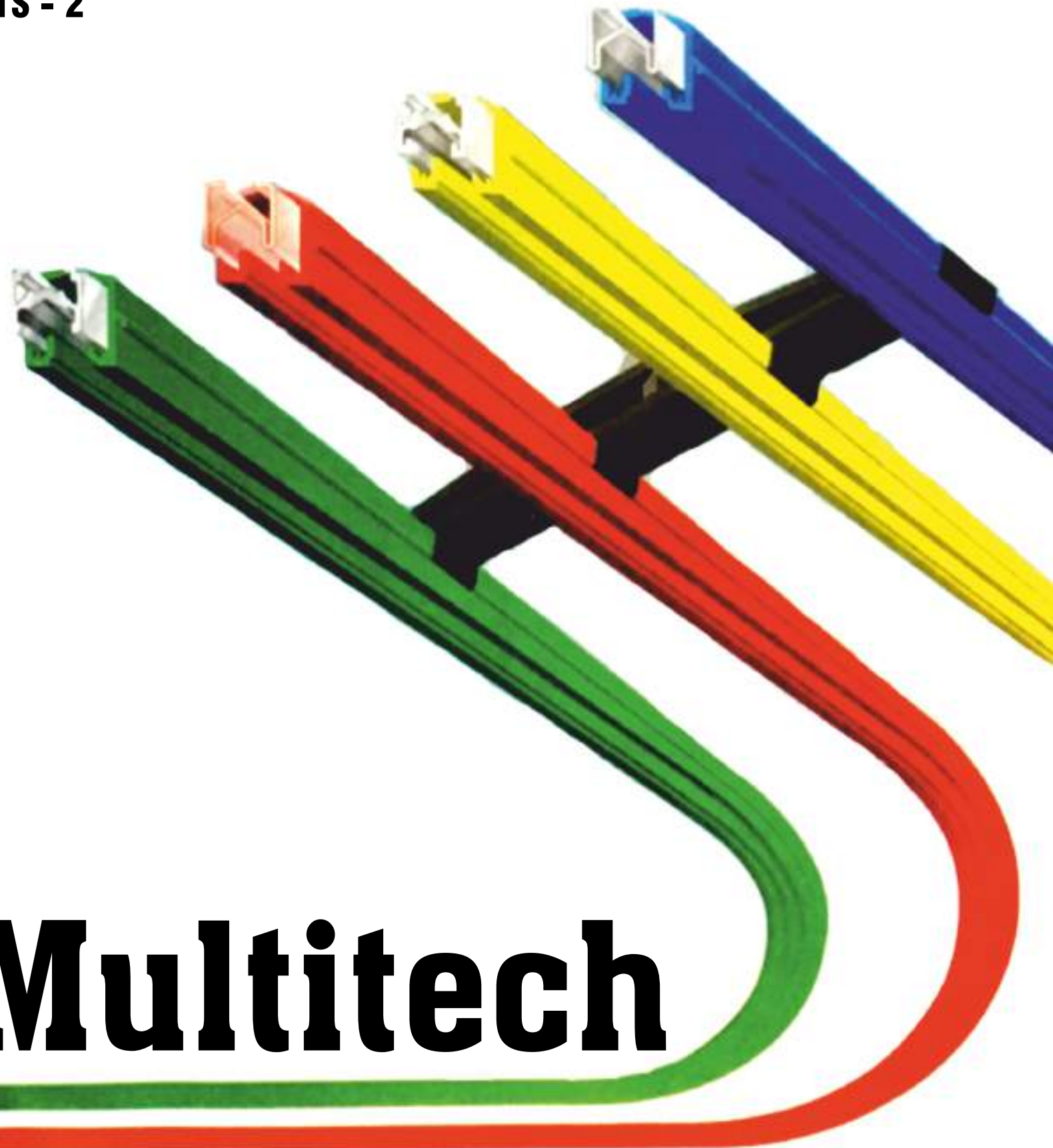

Multitech

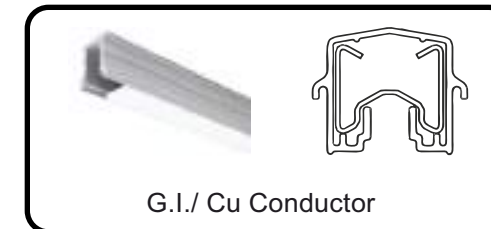

G.I./ Cu Conductor



Al Conductor With S.S Strip



Bolted Joint



Joint Cover



Hanger Clamp



Anchor Clamp

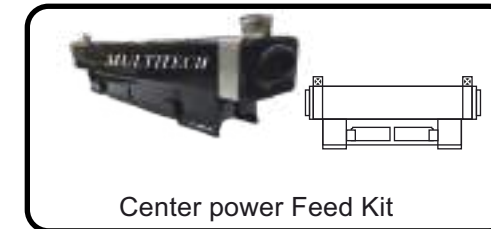

Center power Feed Kit

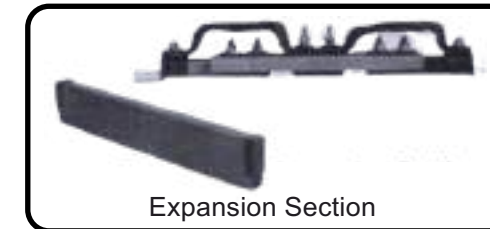

Expansion Section



End Cap

CURRENT COLLECTORS

Heavy Duty Current Collectors are of fully Articulated Design.

This provides multi axis degree of movement thereby allowing compensation of machine motion tolerances and installation variation.

Spring Loaded unit provides positive pressure contact with conductors, thus ensures uninterrupted power transfer during motion.

Variety of designs for different applications and site conditions.

MULTITECH SYSTEMS

Single Pole Current Collector Technical Data



Type	MACC 60	MACC 125	MACC 250
Current Rating	60A	125A	250A
Collector movement Horizontal Vertical	±125 ±50	±200 ±60	±200 ±60
Mounting Bracket	16 sqmm bar	25 sqmm bar	25 sqmm bar
Mounting Distance From conductor contact surface	100mm	127mm	127mm
Sintered Copper Shoe	125A	125A	250A
Shoe Holder	Nylon	Nylon	ABS
Structure	Metallic	Metallic	Metallic

INSTALLATION MULTITECH SYSTEMS can be installed in most atmospheres such as dusty, humid chemical / acidic etc
MAINTENANCE COST No periodic maintenance is required. Only consumable item is contact shoe.



Multitech Systems

Plot No. 48-49, Gali No.6, Krishna Colony, Opp.
Sector-25, Faridabad-121004, Haryana
E-mail : mtscranes@gmail.com | sales@multitechsystems.in
www.multitechsystem.net, 9910705767, 9911723747



9911417747
9560063747
9910043747
9911283747



Multitech Systems

Plot No. 48-49, Gali No.6, Krishna Colony, Opp.
Sector-25, Faridabad-121004, Haryana
E-mail : mtscranes@gmail.com | sales@multitechsystems.in
www.multitechsystem.net, 9910705767, 9911723747



9911417747
9560063747
9910043747
9911283747

Electro-Hydraulic Thruster (18 kg)

Type : ST 520

INTRODUCTION

Electro-hydraulic thruster is a device which develops linear (or force) required to operate the required mechanism. The input to the device is three phase supply. The thrusters are widely used in material handling machines. Thruster in various models develop 18kg to 114kg . In stroke lengths of 51 mm, 76mm 127mm

Thrusters should be mounted with in $\pm 10^\circ$ From vertical. Working fluid - Transformer oil to BS 148.

Technical Data

Thruster Model	ST - 520
Lifting Force	18 Kg
Stroke	51 mm
Current	0.4 amps
Power	90 Watt
Oil Capacity	2 Litters Transformer Oil
Weight	12 Kg
Voltage A. C.	415V 3 ϕ ,AC
Ingress Protection	IP 55 (IS/IEC 600529 : 2001)
Ambient Temperature	50°C Max

★ 380V, 460V, 550V on Enquiry



**Electro-hydraulic Thrusters
ST 520**

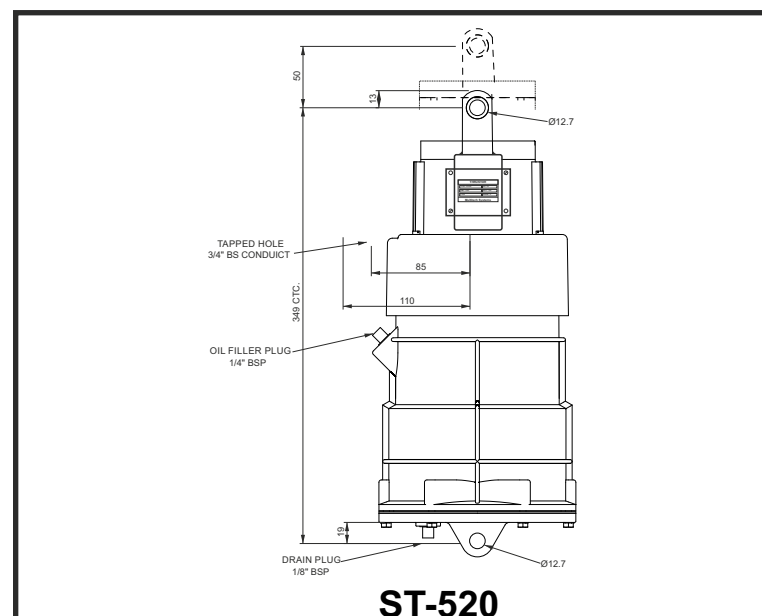
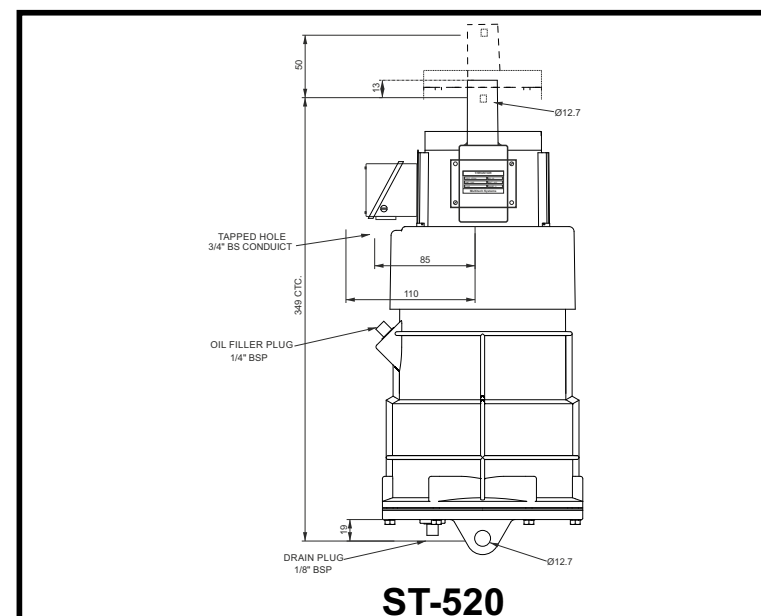

Electro-Hydraulic Thruster (34 kg)

Type : ST 535

INTRODUCTION

Electro-hydraulic thruster is a device which develops linear (or force) required to operate the required mechanism. The input to the device is three phase supply. The thrusters are widely used in material handling machines. Thruster in various models develop 18kg to 114kg . In stroke lengths of 51 mm, 76mm 127mm

Thrusters should be mounted with in $\pm 10^\circ$ From vertical. Working fluid - Transformer oil to BS 148.

Technical Data

Thruster Model	ST - 535
Lifting Force	34 Kg
Stroke	51 mm
Current	0.55 amps
Power	150 Watt
Oil Capacity	2.5 Litters Transformer Oil
Weight	16 Kg
Voltage A. C.	415V 3 ϕ ,AC
Ingress Protection	IP 55 (IS/IEC 600529 : 2001)
Ambient Temperature	50°C Max

★ 380V, 460V, 550V on Enquiry



**Electro-hydraulic Thrusters
ST 535**

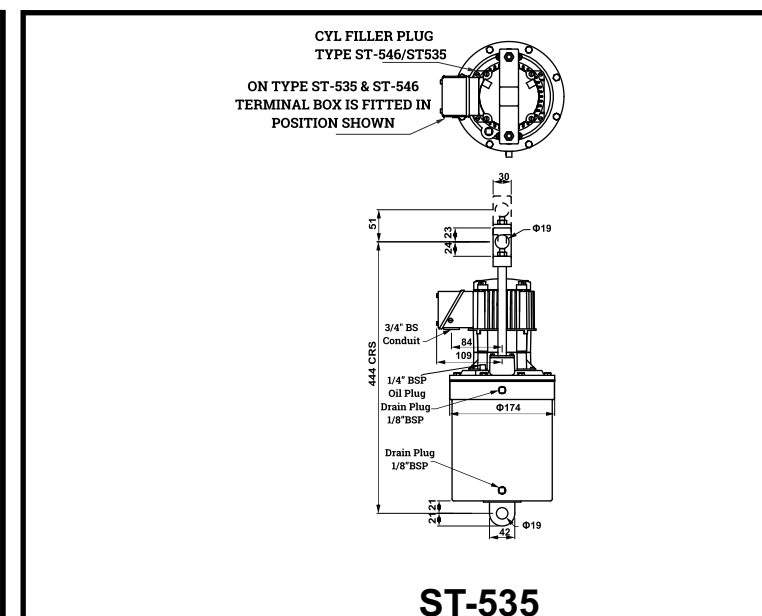
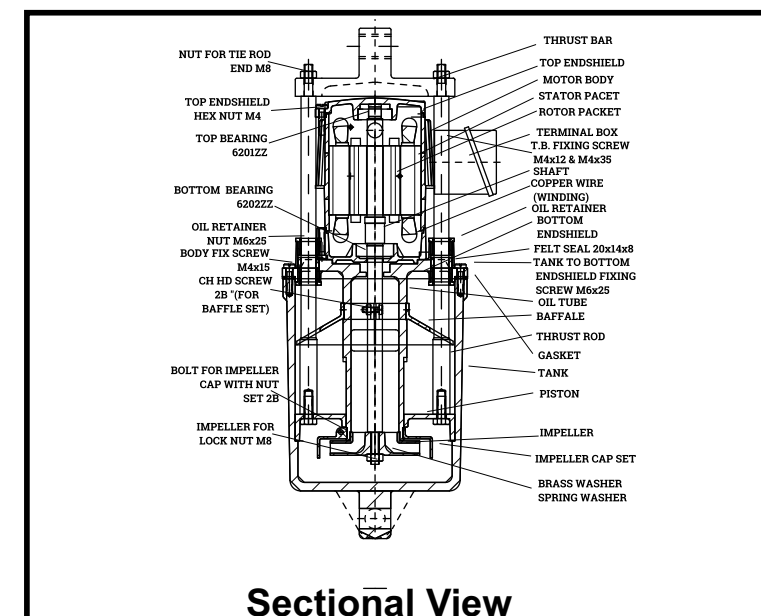

Multitech Systems



Plot No. 48-49, Gali No.6, Krishna Colony, Opp. Sector-25, Faridabad-121004, Haryana
E-mail : mtscranes@gmail.com | sales@multitechsystems.in
www.multitechsystem.net, 9910705767, 9911723747



9911417747
9560063747
9910043747
9911283747

Multitech Systems



Plot No. 48-49, Gali No.6, Krishna Colony, Opp. Sector-25, Faridabad-121004, Haryana
E-mail : mtscranes@gmail.com | sales@multitechsystems.in
www.multitechsystem.net, 9910705767, 9911723747



9911417747
9560063747
9910043747
9911283747

Electro-Hydraulic Thruster (46 kg)

Type : ST 545

INTRODUCTION

Electro-hydraulic thruster is a device which develops linear (or force) required to operate the required mechanism. The input to the device is three phase supply. The thrusters are widely used in material handling machines. Thruster in various models develop 18kg to 114kg . In stroke lengths of 51 mm, 76mm 127mm

Thrusters should be mounted with in $\pm 10^\circ$ From vertical. Working fluid - Transformer oil to BS 148.

Technical Data

Thruster Model	ST - 545
Lifting Force	46 Kg
Stroke	51 mm
Current	0.6 amps
Power	180 Watt
Oil Capacity	2.5 Litters Transformer Oil
Weight	18 Kg
Voltage A. C.	415V 3 ϕ ,AC
Ingress Protection	IP 55 (IS/IEC 600529 : 2001)
Ambient Temperature	50°C Max

* 380V, 460V, 550V on Enquiry



**Electro-hydraulic Thrusters
ST 545**

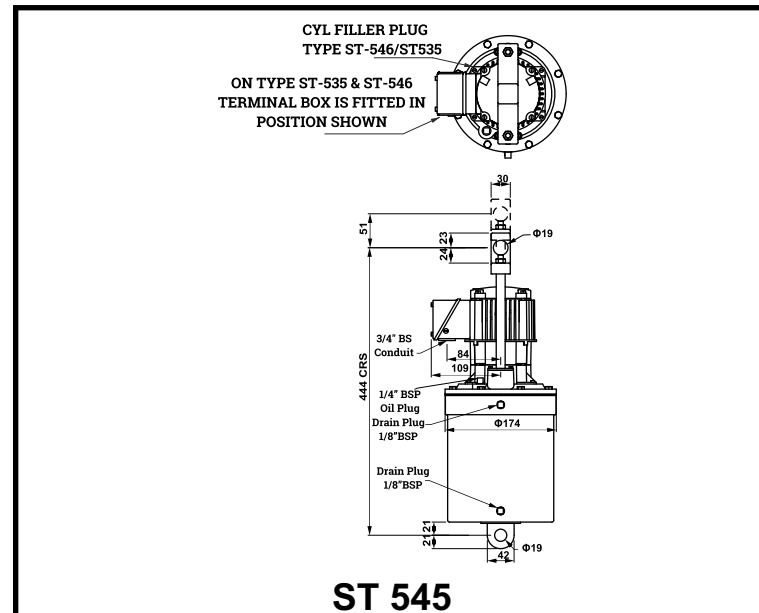
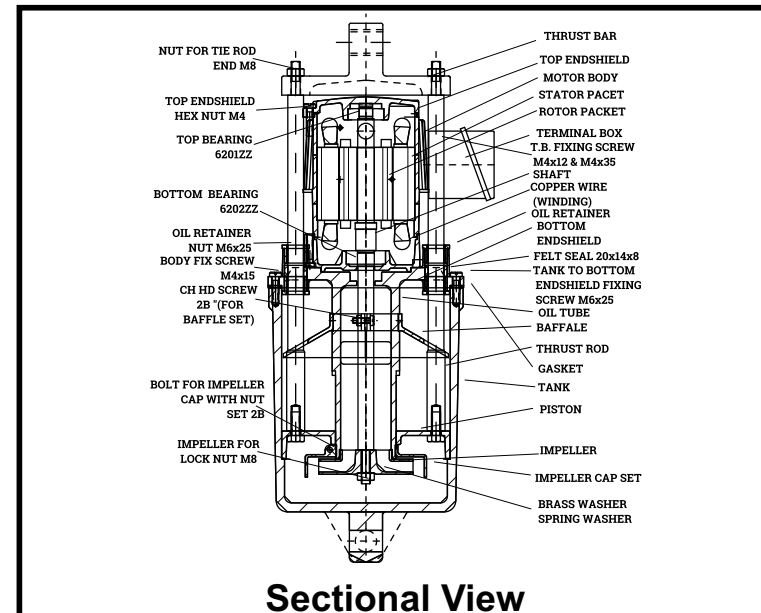

Electro-Hydraulic Thruster (68 kg)

Type : ST 870

INTRODUCTION

Electro-hydraulic thruster is a device which develops linear (or force) required to operate the required mechanism. The input to the device is three phase supply. The thrusters are widely used in material handling machines. Thruster in various models develop 18kg to 114kg . In stroke lengths of 51 mm, 76mm 127mm

Thrusters should be mounted with in $\pm 10^\circ$ From vertical. Working fluid - Transformer oil to BS 148.

Technical Data

Thruster Model	ST - 870
Lifting Force	68 Kg
Stroke	76 mm
Current	0.7 amps
Power	200 Watt
Oil Capacity	4.5 Litters Transformer Oil
Weight	30 Kg
Voltage A. C.	415V 3 ϕ ,AC
Ingress Protection	IP 55 (IS/IEC 600529 : 2001)
Ambient Temperature	50°C Max

* 380V, 460V, 550V on Enquiry



**Electro-hydraulic Thrusters
ST 870**

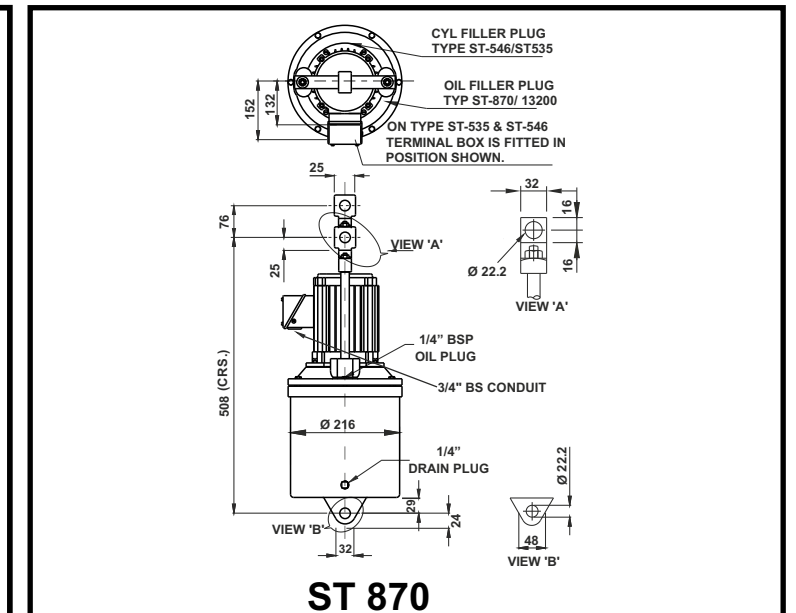
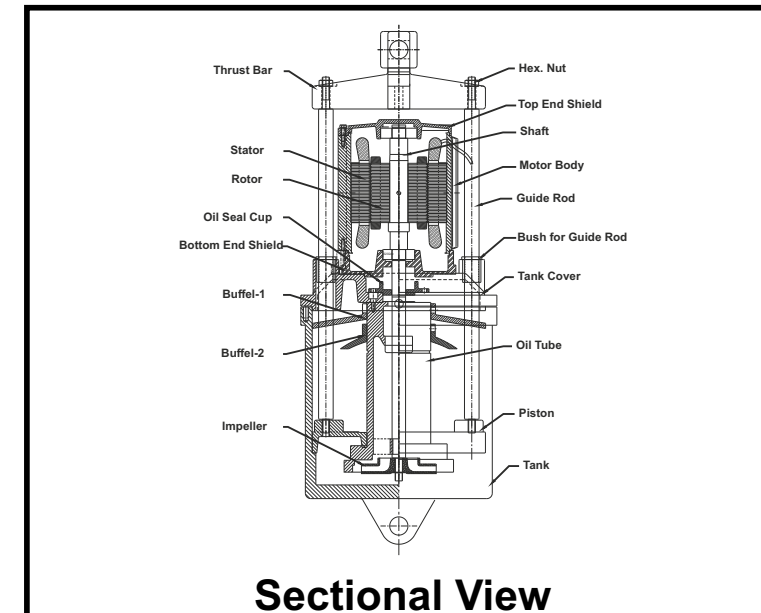

Multitech Systems

Plot No. 48-49, Gali No.6, Krishna Colony, Opp. Sector-25, Faridabad-121004, Haryana
E-mail : mtscranes@gmail.com | sales@multitechsystems.in
www.multitechsystem.net, 9910705767, 9911723747



9911417747
9560063747
9910043747
9911283747



Multitech Systems

Plot No. 48-49, Gali No.6, Krishna Colony, Opp. Sector-25, Faridabad-121004, Haryana
E-mail : mtscranes@gmail.com | sales@multitechsystems.in
www.multitechsystem.net, 9910705767, 9911723747



9911417747
9560063747
9910043747
9911283747

Electro-Hydraulic Thruster (114 kg)

Type : ST 8110

INTRODUCTION

Electro-hydraulic thruster is a device which develops linear (or force) required to operate the required mechanism. The input to the device is three phase supply. The thrusters are widely used in material handling machines. Thruster in various models develop 18kg to 114kg . In stroke lengths of 51 mm, 76mm 127mm

Thrusters should be mounted with in $\pm 10^\circ$ From vertical. Working fluid - Transformer oil to BS 148.

Technical Data

Thruster Model	ST - 8110
Lifting Force	114 Kg
Stroke	76 mm
Current	0.8 amps
Power	250 Watt
Oil Capacity	4.5 Liters Transformer Oil
Weight	35 Kg
Voltage A. C.	415V 3Ø,AC
Ingress Protection	IP 55 (IS/IEC 600529 : 2001)
Ambient Temperature	50°C Max

★ 380V, 460V, 550V on Enquiry



Electro-hydraulic Thrusters
ST8110

MDT 100-18 Mill Duty Thruster Brakes

INTRODUCTION

Thruster Brake is device to retard the speed of moving machinery and to stop it accurately to the desired position. The breaking force is applied to the brake shoes by a pre-stressed compression spring. The shoes press on the rotating brake drum retarding its speed, and finally stopping it.



Technical Data

Item	Brake	Thruster
Model	MDT - 100-18	ST-520
Drum Dia	100 mm	-
Brake Shoe	Asbestos free/BA	-
Braking Torque	6 Kg-m	-
Thrust	-	18Kg
Stroke	-	51mm
Oil + Capacity	-	Transformer Oil 2 Litrs
Rated Voltage	-	415V±10%,3Ph AC,50Hz
Current At 415 V AC	-	0.4 Amps
Insulation	-	F Class
Ingress Protection	-	IP-44 IS/IEC 60529 (2001)
Surface Temperature		+50°C
Weight	9 kg	12 kg
Painting	Colour RAL 7021	

Selection of Brake Size

Electo-hydraulic thruster is a device which develops liner thrust (or force) required to operate the required mechanism. The input to the device is three phase supply.

The brake torque must be \Rightarrow than motor full load as referred with drum. Formula as below:

$$T = \text{Torque in Kgm} = \frac{716 \times \text{Hp}}{\text{rpm}}$$

$$T = \text{Torque in Nm} = \frac{9552 \times \text{Kw}}{\text{rpm}}$$

Where Hp/Kw = motor output & rpm = Rev/minute

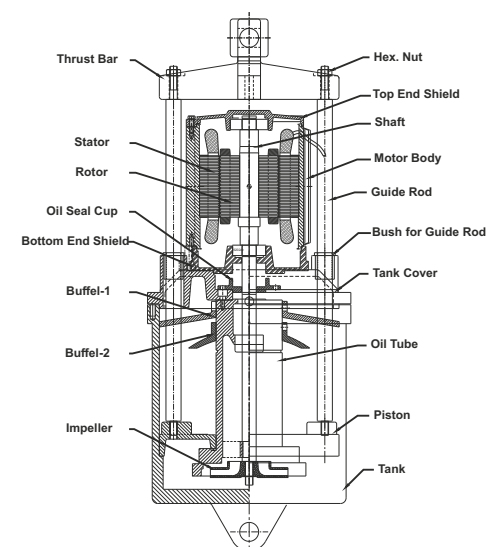

Sectional View

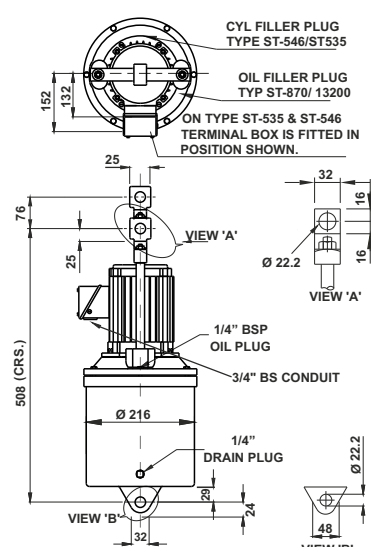

ST 8110

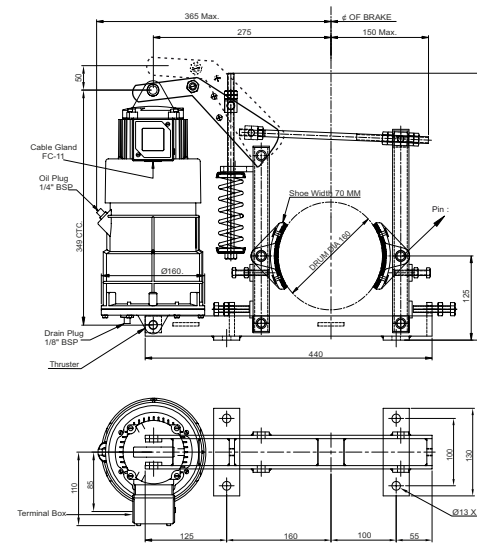

MDT-100-18

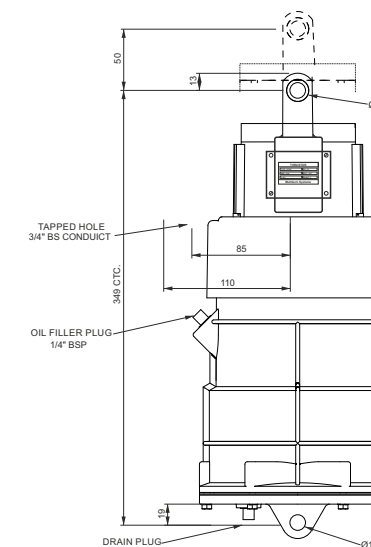

ST-520



Multitech Systems

Plot No. 48-49, Gali No.6, Krishna Colony, Opp. Sector-25, Faridabad-121004, Haryana

E-mail : mtscranes@gmail.com | sales@multitechsystems.in
www.multitechsystem.net, 9910705767, 9911723747



9911417747
9560063747
9910043747
9911283747



Multitech Systems

Plot No. 48-49, Gali No.6, Krishna Colony, Opp. Sector-25, Faridabad-121004, Haryana

E-mail : mtscranes@gmail.com | sales@multitechsystems.in
www.multitechsystem.net, 9910705767, 9911723747



9911417747
9560063747
9910043747
9911283747

MDT 150-18

Mill Duty Thruster Brakes

INTRODUCTION

Thruster Brake is device to retard the speed of moving machinery and to stop it accurately to the desired position. The breaking force is applied to the brake shoes by a pre-stressed compression spring. The shoes press on the rotating brake drum retarding its speed, and finally stopping it.

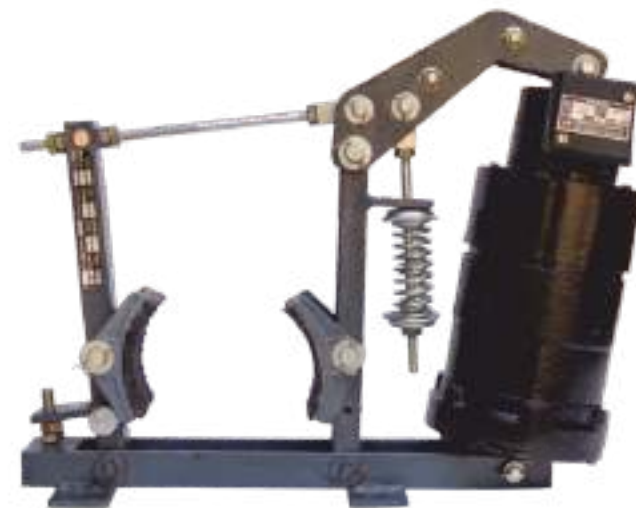

Technical Data

Item	Brake	Thruster
Model	MDT - 150-18	ST-520
Drum Dia	150 mm	-
Brake Shoe	Asbestos free/BA	-
Braking Torque	7.5 Kg-m	-
Thrust	-	18Kg
Stroke	-	51mm
Oil + Capacity	-	Transformer Oil 2 Litrs
Rated Voltage	-	415V±10%,3Ph AC,50Hz
Current At 415 V AC	-	0.4 Amps
Insulation	-	F Class
Ingress Protection	-	IP-44 IS/IEC 60529 (2001)
Surface Temperature	-	+50°C
Weight	11 kg	12 kg
Painting	Colour RAL 7021	

Selection of Brake Size

Electo-hydraulic thruster is a device which develops liner thrust (or force) required to operate the required mechanism. The input to the device is three phase supply.

The brake torque must be => than motor full load as referred with drum. Formula as below:

$$T = \text{Torque in Kgm} = \frac{716 \times \text{Hp}}{\text{rpm}}$$

$$T = \text{Torque in Nm} = \frac{9552 \times \text{Kw}}{\text{rpm}}$$

Where Hp/Kw = motor output & rpm = Rev/minute

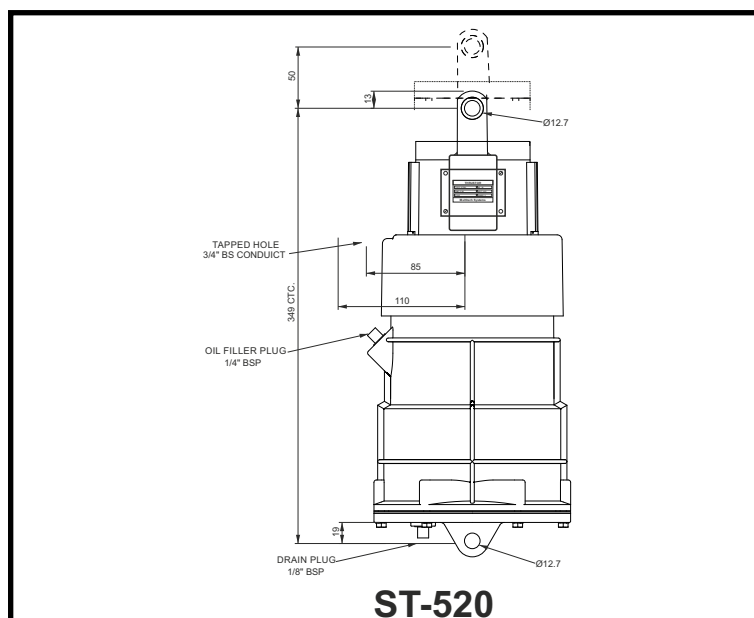
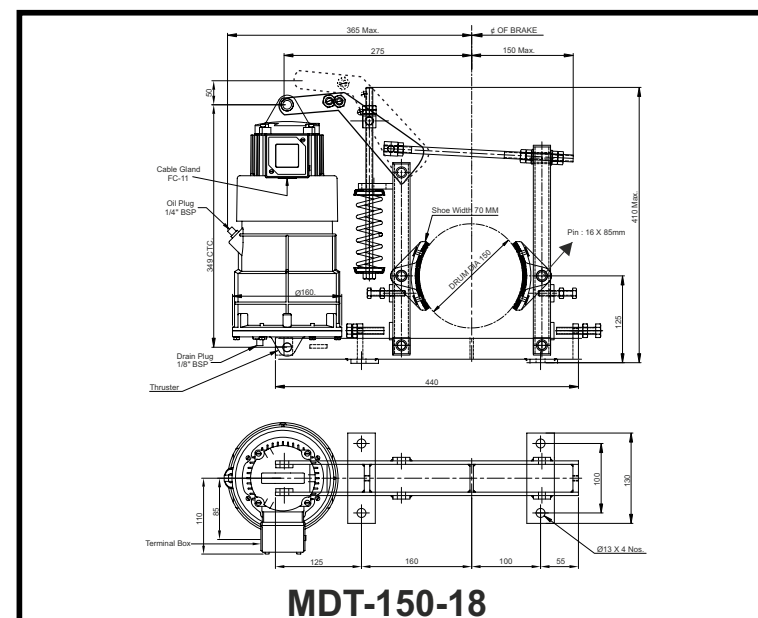

MDT 160-18

Mill Duty Thruster Brakes

INTRODUCTION

Thruster Brake is device to retard the speed of moving machinery and to stop it accurately to the desired position. The breaking force is applied to the brake shoes by a pre-stressed compression spring. The shoes press on the rotating brake drum retarding its speed, and finally stopping it.

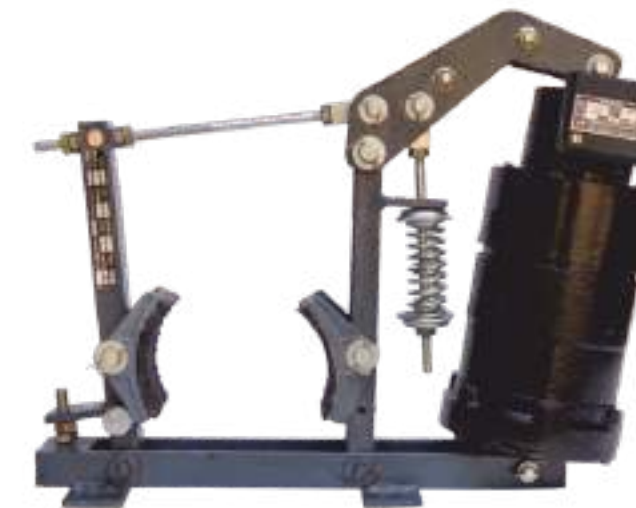

Technical Data

Item	Brake	Thruster
Model	MDT - 160-18	ST-520
Drum Dia	160 mm	-
Brake Shoe	Asbestos free/BA	-
Braking Torque	9 Kg-m	-
Thrust	-	18Kg
Stroke	-	51mm
Oil + Capacity	-	Transformer Oil 2 Litrs
Rated Voltage	-	415V±10%,3Ph AC,50Hz
Current At 415 V AC	-	0.4 Amps
Insulation	-	F Class
Ingress Protection	-	IP-44 IS/IEC 60529 (2001)
Surface Temperature	-	+50°C
Weight	11 kg	12 kg
Painting	Colour RAL 7021	

Selection of Brake Size

Electo-hydraulic thruster is a device which develops liner thrust (or force) required to operate the required mechanism. The input to the device is three phase supply.

The brake torque must be => than motor full load as referred with drum. Formula as below:

$$T = \text{Torque in Kgm} = \frac{716 \times \text{Hp}}{\text{rpm}}$$

$$T = \text{Torque in Nm} = \frac{9552 \times \text{Kw}}{\text{rpm}}$$

Where Hp/Kw = motor output & rpm = Rev/minute

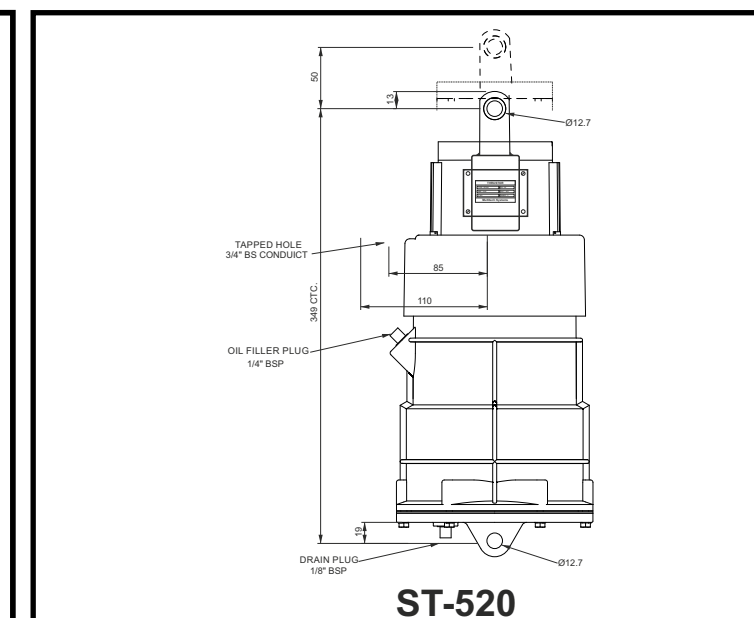
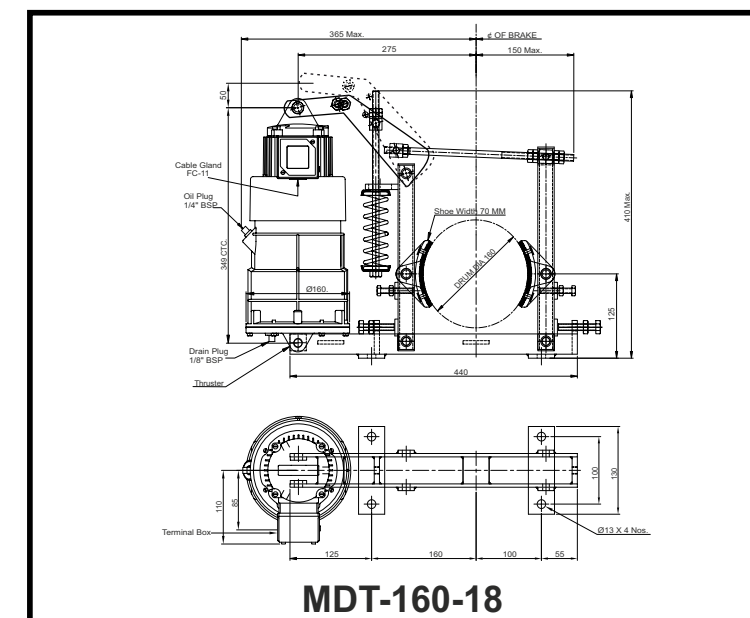

Multitech Systems

Plot No. 48-49, Gali No.6, Krishna Colony, Opp. Sector-25, Faridabad-121004, Haryana
E-mail : mtscranes@gmail.com | sales@multitechsystems.in
www.multitechsystem.net, 9910705767, 9911723747



9911417747
9560063747
9910043747
9911283747



Multitech Systems

Plot No. 48-49, Gali No.6, Krishna Colony, Opp. Sector-25, Faridabad-121004, Haryana
E-mail : mtscranes@gmail.com | sales@multitechsystems.in
www.multitechsystem.net, 9910705767, 9911723747



9911417747
9560063747
9910043747
9911283747

MDT 200-18

Mill Duty Thruster Brakes

INTRODUCTION

Thruster Brake is device to retard the speed of moving machinery and to stop it accurately to the desired position. The breaking force is applied to the brake shoes by a pre-stressed compression spring. The shoes press on the rotating brake drum retarding its speed, and finally stopping it.

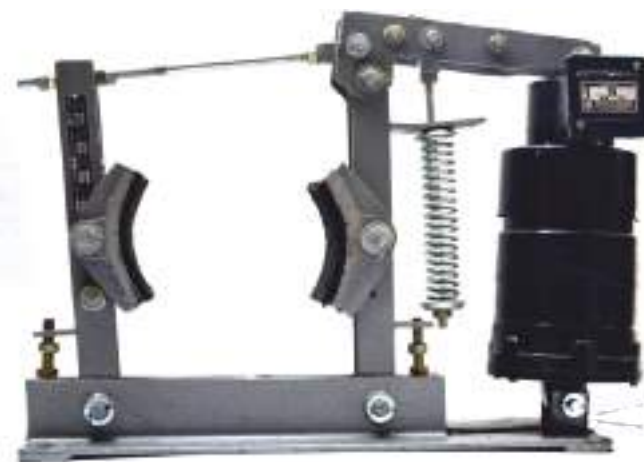

Technical Data

Item	Brake	Thruster
Model	MDT - 200-18	ST-520
Drum Dia	200 mm	-
Brake Shoe	Asbestos free/BA	-
Braking Torque	20 Kg-m	-
Thrust	-	18Kg
Stroke	-	51mm
Oil + Capacity	-	Transformer Oil 2 Litrs
Rated Voltage	-	415V±10%,3Ph AC,50Hz
Current At 415 V AC	-	0.4 Amps
Insulation	-	F Class
Ingress Protection	-	IP-44 IS/IEC 60529 (2001)
Surface Temperature	-	+50°C
Weight	18 kg	12 kg
Painting	Colour RAL 7021	

Selection of Brake Size

Electo-hydraulic thruster is a device which develops liner thrust (or force) required to operate the required mechanism. The input to the device is three phase supply.

The brake torque must be => than motor full load as referred with drum. Formula as below:

$$T = \text{Torque in Kgm} = \frac{716 \times \text{Hp}}{\text{rpm}}$$

$$T = \text{Torque in Nm} = \frac{9552 \times \text{Kw}}{\text{rpm}}$$

Where Hp/Kw = motor output & rpm = Rev/minute

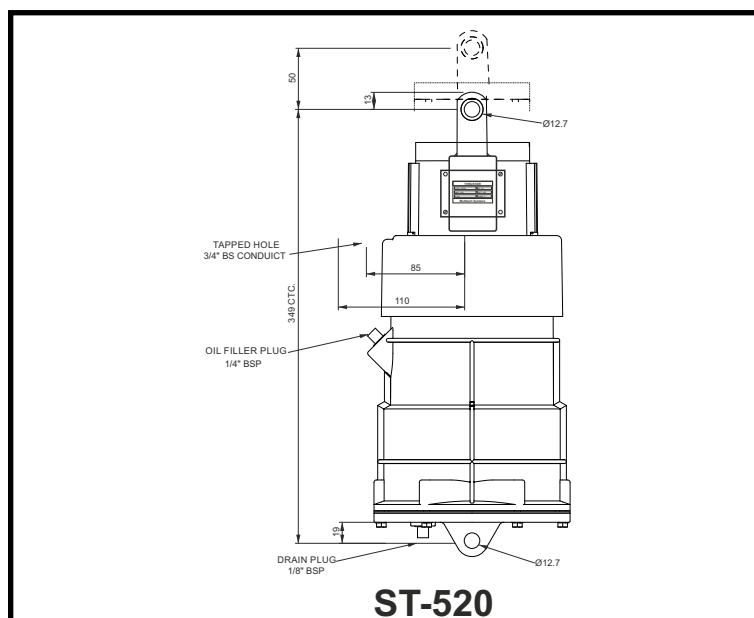
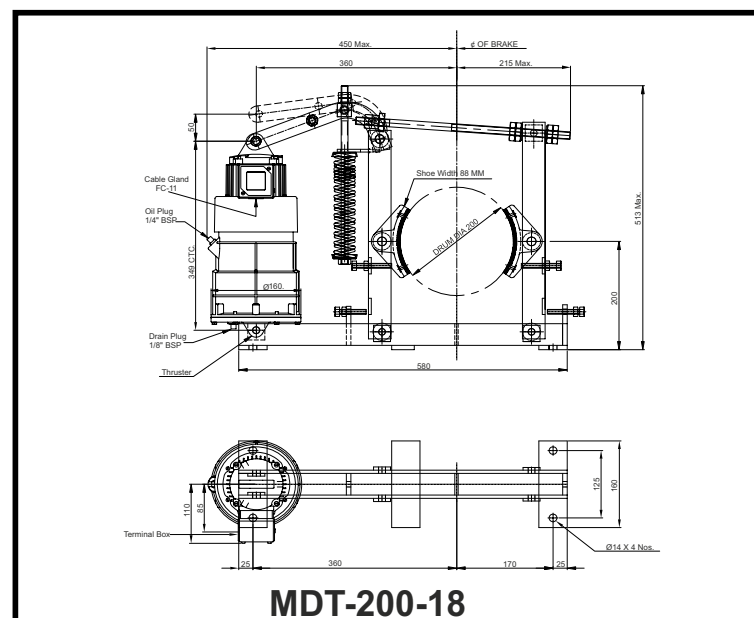

MDT 200-34

Mill Duty Thruster Brakes

INTRODUCTION

Thruster Brake is device to retard the speed of moving machinery and to stop it accurately to the desired position. The breaking force is applied to the brake shoes by a pre-stressed compression spring. The shoes press on the rotating brake drum retarding its speed, and finally stopping it.

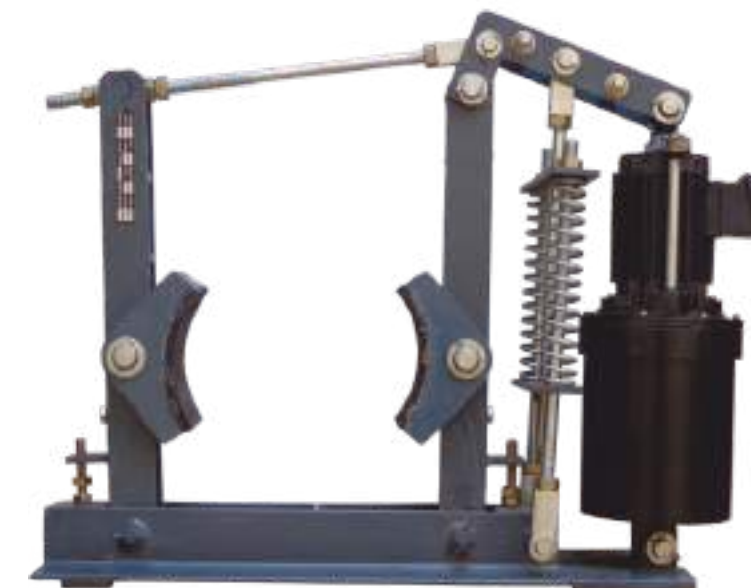

Technical Data

Item	Brake	Thruster
Model	MDT - 200-34	ST-535
Drum Dia	200 mm	-
Brake Shoe	Asbestos free/BA	-
Braking Torque	32 Kg-m	-
Thrust	-	34Kg
Stroke	-	51mm
Oil + Capacity	-	Transformer Oil 2 Litrs
Rated Voltage	-	415V±10%,3Ph AC,50Hz
Current At 415 V AC	-	0.5 Amps
Insulation	-	F Class
Ingress Protection	-	IP-44 IS/IEC 60529 (2001)
Surface Temperature	-	+50°C
Weight	24 kg	16 kg
Painting	Colour RAL 7021	

Selection of Brake Size

Electo-hydraulic thruster is a device which develops liner thrust (or force) required to operate the required mechanism. The input to the device is three phase supply.

The brake torque must be => than motor full load as referred with drum. Formula as below:

$$T = \text{Torque in Kgm} = \frac{716 \times \text{Hp}}{\text{rpm}}$$

$$T = \text{Torque in Nm} = \frac{9552 \times \text{Kw}}{\text{rpm}}$$

Where Hp/Kw = motor output & rpm = Rev/minute

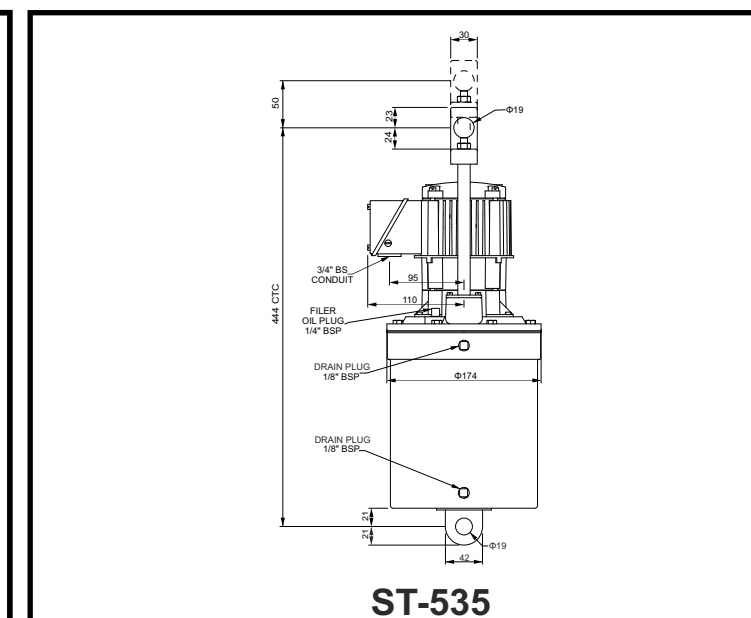
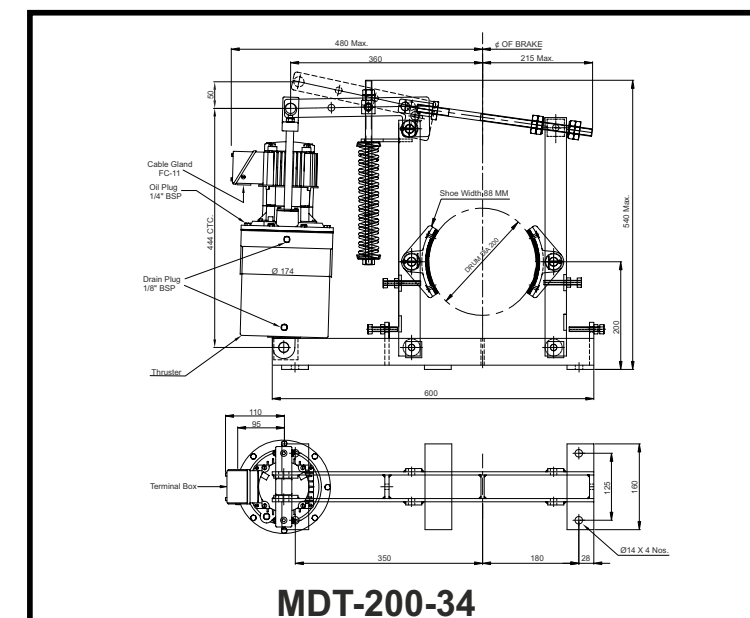

Multitech Systems

Plot No. 48-49, Gali No.6, Krishna Colony, Opp. Sector-25, Faridabad-121004, Haryana
E-mail : mtscranes@gmail.com | sales@multitechsystems.in
www.multitechsystem.net, 9910705767, 9911723747



9911417747
9560063747
9910043747
9911283747



Multitech Systems

Plot No. 48-49, Gali No.6, Krishna Colony, Opp. Sector-25, Faridabad-121004, Haryana
E-mail : mtscranes@gmail.com | sales@multitechsystems.in
www.multitechsystem.net, 9910705767, 9911723747



9911417747
9560063747
9910043747
9911283747

MDT 250-18

Mill Duty Thruster Brakes

INTRODUCTION

Thruster Brake is device to retard the speed of moving machinery and to stop it accurately to the desired position. The breaking force is applied to the brake shoes by a pre-stressed compression spring. The shoes press on the rotating brake drum retarding its speed, and finally stopping it.

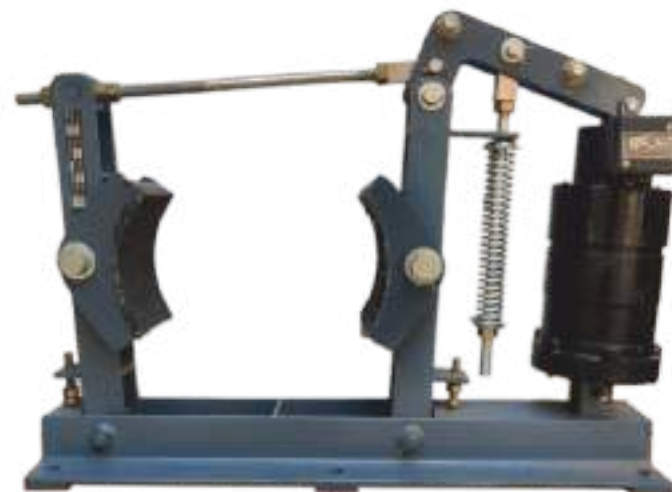

Technical Data

Item	Brake	Thruster
Model	MDT - 250-18	ST-520
Drum Dia	250 mm	-
Brake Shoe	Asbestos free/BA	-
Braking Torque	35 Kg-m	-
Thrust	-	18Kg
Stroke	-	51mm
Oil + Capacity	-	Transformer Oil 2 Litrs
Rated Voltage	-	415V±10%,3Ph AC,50Hz
Current At 415 V AC	-	0.4 Amps
Insulation	-	F Class
Ingress Protection	-	IP-44 IS/IEC 60529 (2001)
Surface Temperature	-	+50°C
Weight	23 kg	12 kg
Painting	Colour RAL 7021	

Selection of Brake Size

Electo-hydraulic thruster is a device which develops liner thrust (or force) required to operate the required mechanism. The input to the device is three phase supply.

The brake torque must be => than motor full load as referred with drum. Formula as below:

$$T = \text{Torque in Kgm} = \frac{716 \times \text{Hp}}{\text{rpm}}$$

$$T = \text{Torque in Nm} = \frac{9552 \times \text{Kw}}{\text{rpm}}$$

Where Hp/Kw = motor output & rpm = Rev/minute

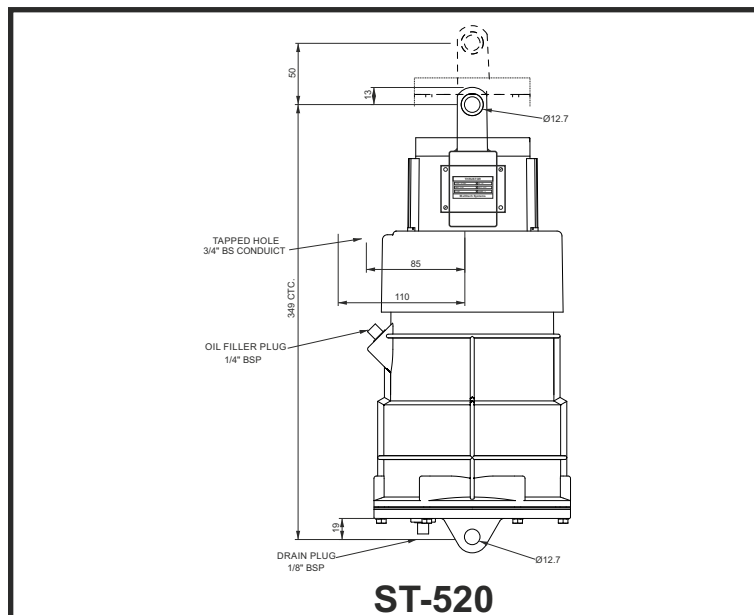
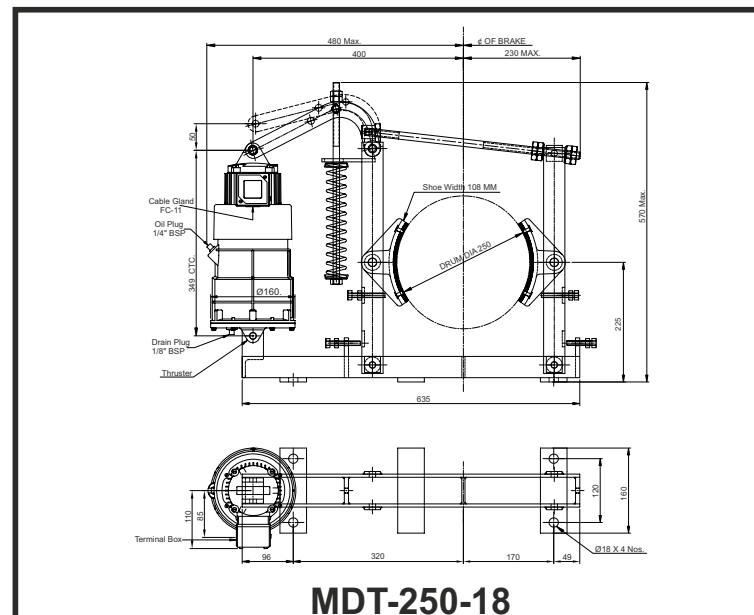

MDT 250-34

Mill Duty Thruster Brakes

INTRODUCTION

Thruster Brake is device to retard the speed of moving machinery and to stop it accurately to the desired position. The breaking force is applied to the brake shoes by a pre-stressed compression spring. The shoes press on the rotating brake drum retarding its speed, and finally stopping it.

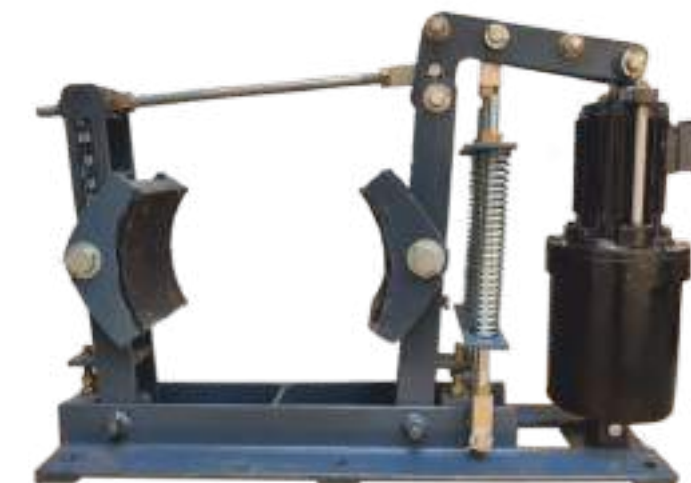

Technical Data

Item	Brake	Thruster
Model	MDT - 250-34	ST-535
Drum Dia	250 mm	-
Brake Shoe	Asbestos free/BA	-
Braking Torque	42 Kg-m	-
Thrust	-	34Kg
Stroke	-	51mm
Oil + Capacity	-	Transformer Oil 2 Litrs
Rated Voltage	-	415V±10%,3Ph AC,50Hz
Current At 415 V AC	-	0.5 Amps
Insulation	-	F Class
Ingress Protection	-	IP-55 IS/IEC 60529 (2001)
Surface Temperature	-	+50°C
Weight	29 kg	16 kg
Painting	Colour RAL 7021	

Selection of Brake Size

Electo-hydraulic thruster is a device which develops liner thrust (or force) required to operate the required mechanism. The input to the device is three phase supply.

The brake torque must be => than motor full load as referred with drum. Formula as below:

$$T = \text{Torque in Kgm} = \frac{716 \times \text{Hp}}{\text{rpm}}$$

$$T = \text{Torque in Nm} = \frac{9552 \times \text{Kw}}{\text{rpm}}$$

Where Hp/Kw = motor output & rpm = Rev/minute

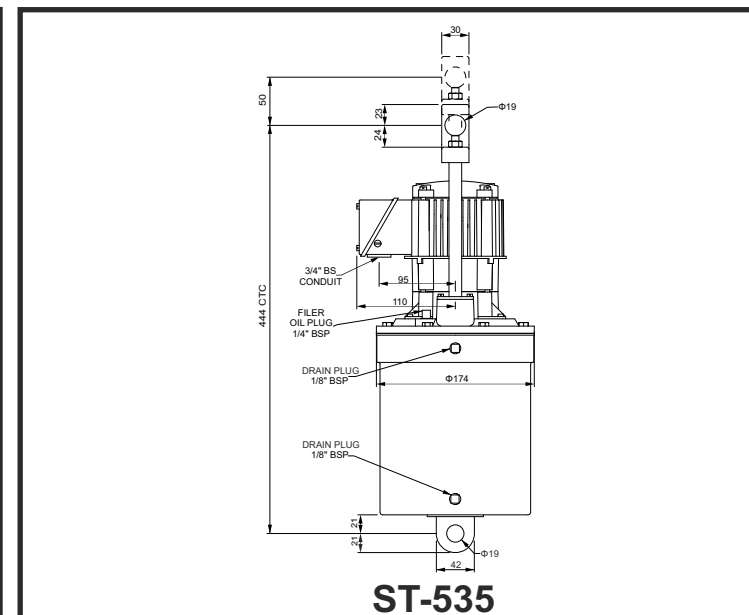
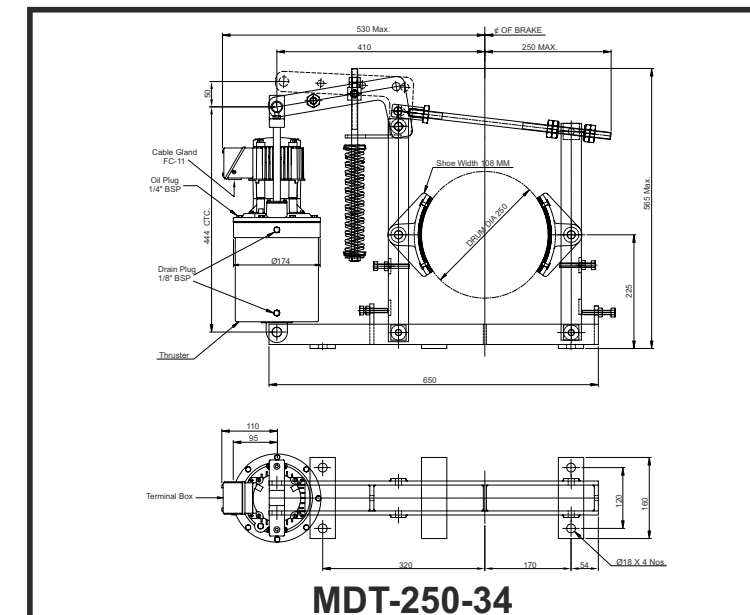

Multitech Systems

Plot No. 48-49, Gali No.6, Krishna Colony, Opp. Sector-25, Faridabad-121004, Haryana
E-mail : mtscranes@gmail.com | sales@multitechsystems.in
www.multitechsystem.net, 9910705767, 9911723747



9911417747
9560063747
9910043747
9911283747



Multitech Systems

Plot No. 48-49, Gali No.6, Krishna Colony, Opp. Sector-25, Faridabad-121004, Haryana
E-mail : mtscranes@gmail.com | sales@multitechsystems.in
www.multitechsystem.net, 9910705767, 9911723747



9911417747
9560063747
9910043747
9911283747

MDT 300-18

Mill Duty Thruster Brakes

INTRODUCTION

Thruster Brake is device to retard the speed of moving machinery and to stop it accurately to the desired position. The breaking force is applied to the brake shoes by a pre-stressed compression spring. The shoes press on the rotating brake drum retarding its speed, and finally stopping it.

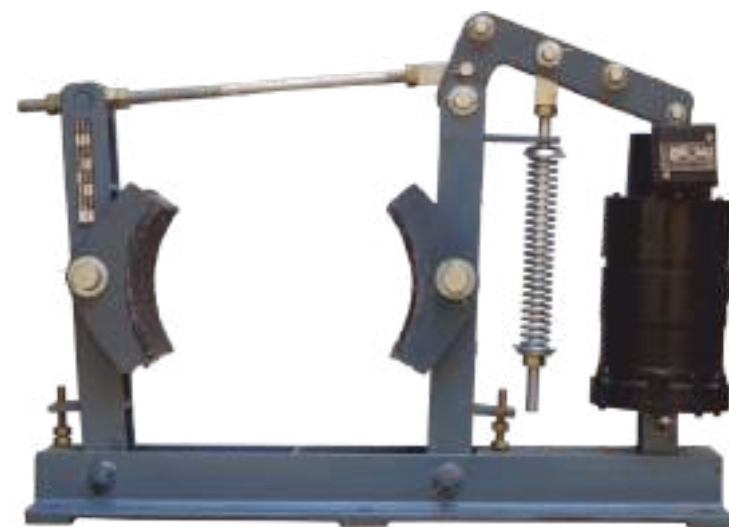

Technical Data

Item	Brake	Thruster
Model	MDT - 300-18	ST-520
Drum Dia	300 mm	-
Brake Shoe	Asbestos free/BA	-
Braking Torque	42 Kg-m	-
Thrust	-	18Kg
Stroke	-	51mm
Oil + Capacity	-	Transformer Oil 2 Litrs
Rated Voltage	-	415V±10%,3Ph AC,50Hz
Current At 415 V AC	-	0.4 Amps
Insulation	-	F Class
Ingress Protection	-	IP-44 IS/IEC 60529 (2001)
Surface Temperature	-	+50°C
Weight	26 kg	12 kg
Painting	Colour RAL 7021	

Selection of Brake Size

Electo-hydraulic thruster is a device which develops liner thrust (or force) required to operate the required mechanism. The input to the device is three phase supply.

The brake torque must be => than motor full load as referred with drum. Formula as below:

$$T = \text{Torque in Kgm} = \frac{716 \times \text{Hp}}{\text{rpm}}$$

$$T = \text{Torque in Nm} = \frac{9552 \times \text{Kw}}{\text{rpm}}$$

Where Hp/Kw = motor output & rpm = Rev/minute

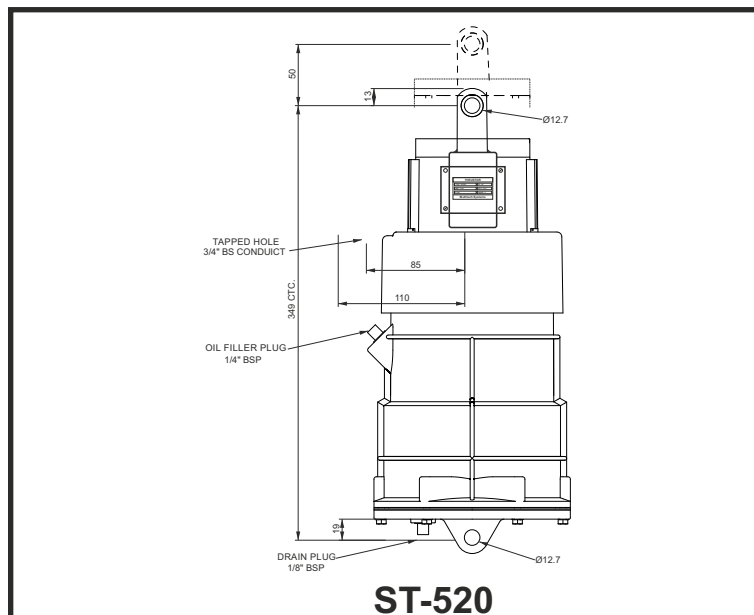
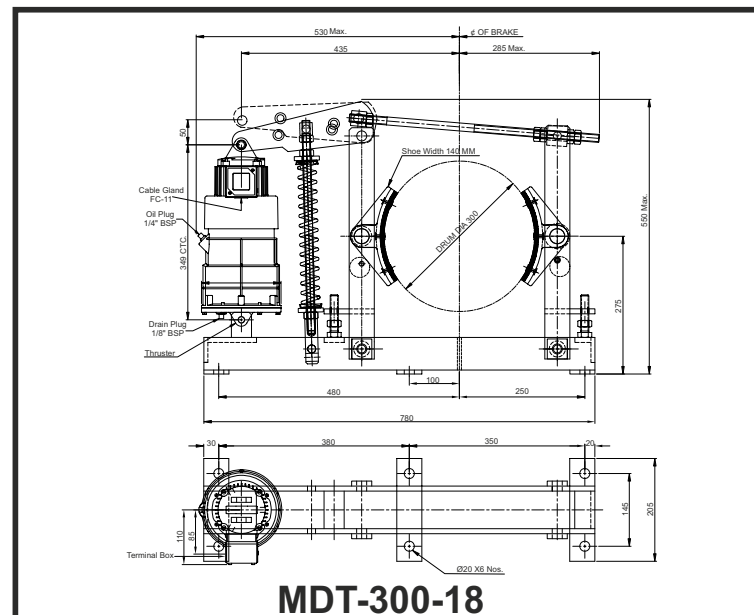

MDT 300-34

Mill Duty Thruster Brakes

INTRODUCTION

Thruster Brake is device to retard the speed of moving machinery and to stop it accurately to the desired position. The breaking force is applied to the brake shoes by a pre-stressed compression spring. The shoes press on the rotating brake drum retarding its speed, and finally stopping it.

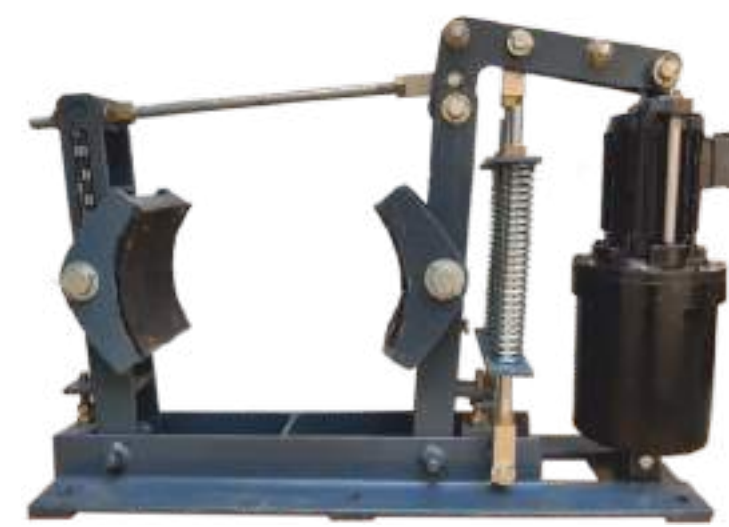

Technical Data

Item	Brake	Thruster
Model	MDT - 300-34	ST-535
Drum Dia	300 mm	-
Brake Shoe	Asbestos free/BA	-
Braking Torque	62 Kg-m	-
Thrust	-	34Kg
Stroke	-	51mm
Oil + Capacity	-	Transformer Oil 2 Litrs
Rated Voltage	-	415V±10%,3Ph AC,50Hz
Current At 415 V AC	-	0.5 Amps
Insulation	-	F Class
Ingress Protection	-	IP-44 IS/IEC 60529 (2001)
Surface Temperature	-	+50°C
Weight	34 kg	16 kg
Painting	Colour RAL 7021	

Selection of Brake Size

Electo-hydraulic thruster is a device which develops liner thrust (or force) required to operate the required mechanism. The input to the device is three phase supply.

The brake torque must be => than motor full load as referred with drum. Formula as below:

$$T = \text{Torque in Kgm} = \frac{716 \times \text{Hp}}{\text{rpm}}$$

$$T = \text{Torque in Nm} = \frac{9552 \times \text{Kw}}{\text{rpm}}$$

Where Hp/Kw = motor output & rpm = Rev/minute

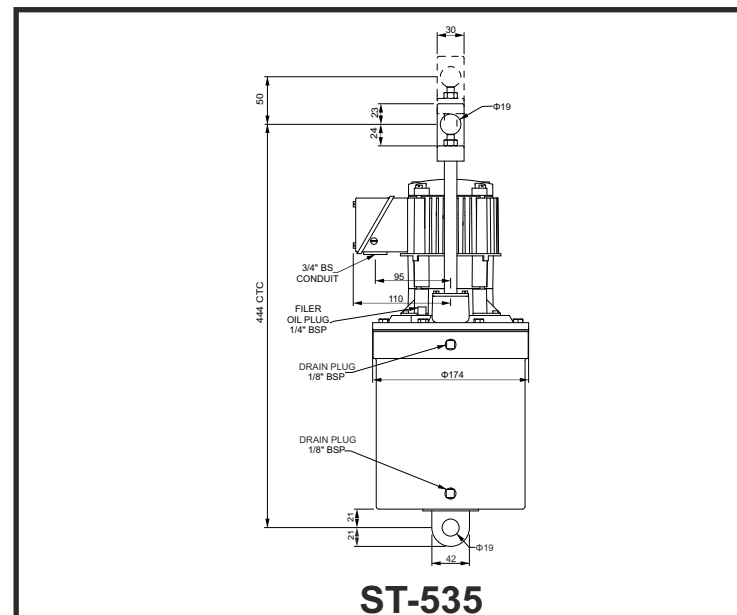
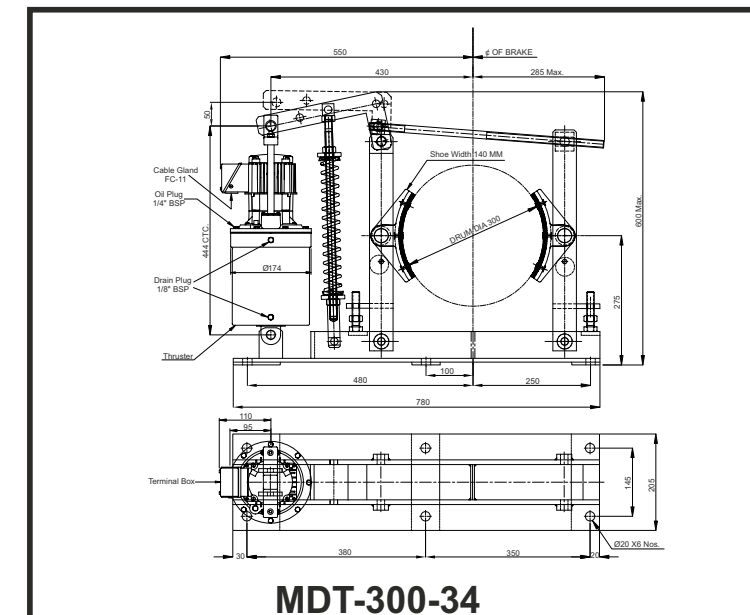

Multitech Systems

Plot No. 48-49, Gali No.6, Krishna Colony, Opp. Sector-25, Faridabad-121004, Haryana
 E-mail : mtscranes@gmail.com | sales@multitechsystems.in
www.multitechsystem.net, 9910705767, 9911723747



9911417747
 9560063747
 9910043747
 9911283747



Multitech Systems

Plot No. 48-49, Gali No.6, Krishna Colony, Opp. Sector-25, Faridabad-121004, Haryana
 E-mail : mtscranes@gmail.com | sales@multitechsystems.in
www.multitechsystem.net, 9910705767, 9911723747



9911417747
 9560063747
 9910043747
 9911283747

MDT 300-46

Mill Duty Thruster Brakes

INTRODUCTION

Thruster Brake is device to retard the speed of moving machinery and to stop it accurately to the desired position. The breaking force is applied to the brake shoes by a pre-stressed compression spring. The shoes press on the rotating brake drum retarding its speed, and finally stopping it.

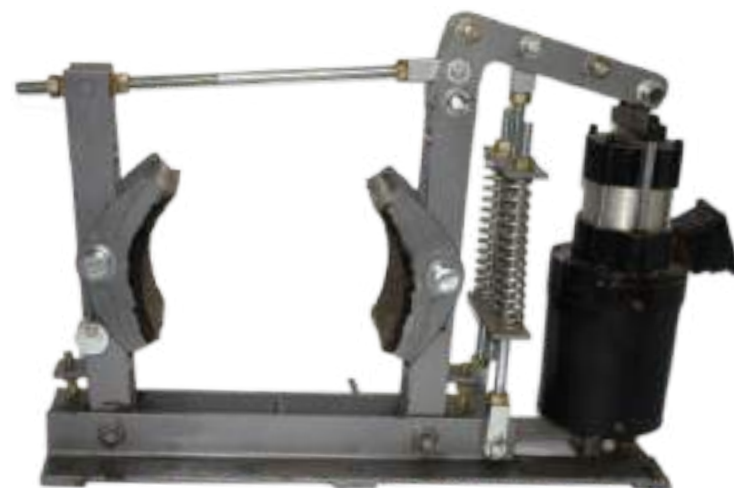

Technical Data

Item	Brake	Thruster
Model	MDT - 300-46	ST-545
Drum Dia	300 mm	-
Brake Shoe	Asbestos free/BA	-
Braking Torque	72 Kg-m	-
Thrust	-	46Kg
Stroke	-	51mm
Oil + Capacity	-	Transformer Oil 2 Litrs
Rated Voltage	-	415V±10%,3Ph AC,50Hz
Current At 415 V AC	-	0.6 Amps
Insulation	-	F Class
Ingress Protection	-	IP-44 IS/IEC 60529 (2001)
Surface Temperature	-	+50°C
Weight	34 kg	18 kg
Painting	Colour RAL 7021	

Selection of Brake Size

Electo-hydraulic thruster is a device which develops liner thrust (or force) required to operate the required mechanism. The input to the device is three phase supply.

The brake torque must be => than motor full load as referred with drum. Formula as below:

$$T = \text{Torque in Kgm} = \frac{716 \times \text{Hp}}{\text{rpm}}$$

$$T = \text{Torque in Nm} = \frac{9552 \times \text{Kw}}{\text{rpm}}$$

Where Hp/Kw = motor output & rpm = Rev/minute

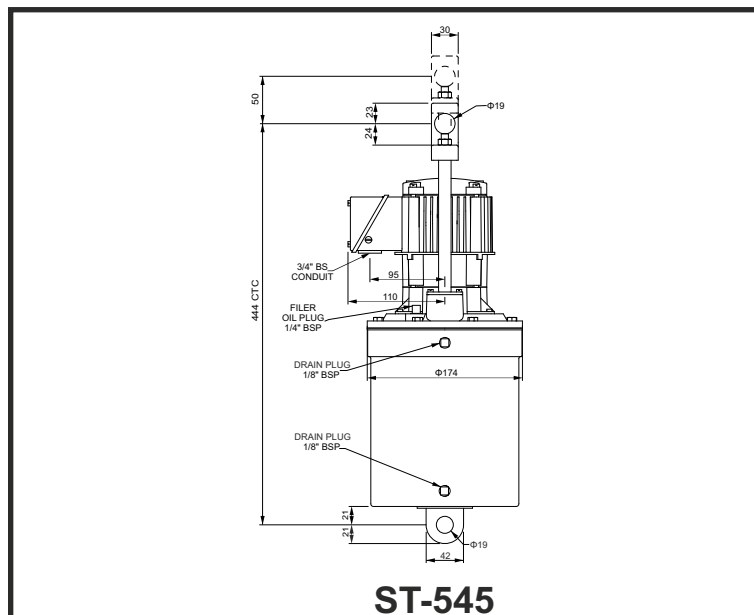
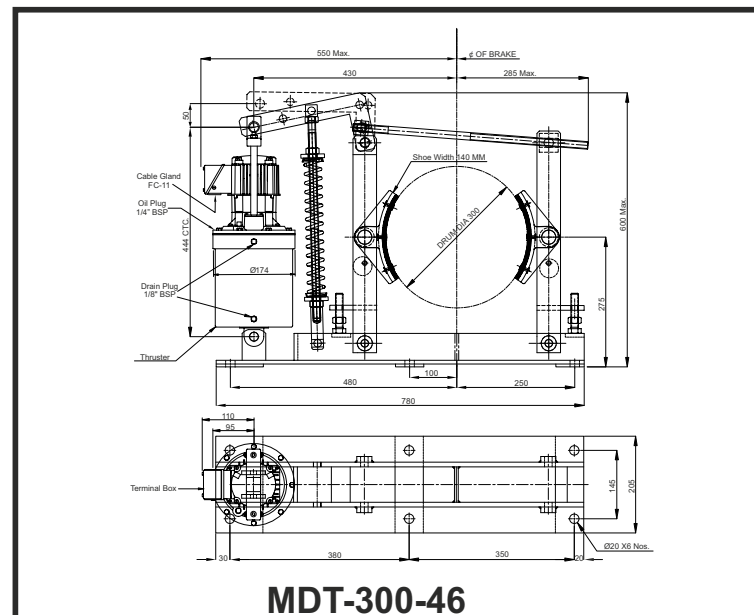

MDT 300-68

Mill Duty Thruster Brakes

INTRODUCTION

Thruster Brake is device to retard the speed of moving machinery and to stop it accurately to the desired position. The breaking force is applied to the brake shoes by a pre-stressed compression spring. The shoes press on the rotating brake drum retarding its speed, and finally stopping it.

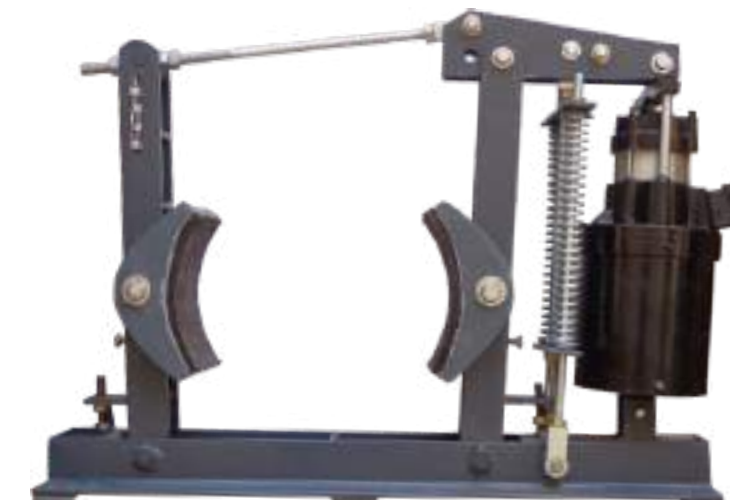

Technical Data

Item	Brake	Thruster
Model	MDT - 300-68	ST-870
Drum Dia	300 mm	-
Brake Shoe	Asbestos free/BA	-
Braking Torque	90 Kg-m	-
Thrust	-	68Kg
Stroke	-	76mm
Oil + Capacity	-	Transformer Oil 2 Litrs
Rated Voltage	-	415V±10%,3Ph AC,50Hz
Current At 415 V AC	-	0.7 Amps
Insulation	-	F Class
Ingress Protection	-	IP-55 IS/IEC 60529 (2001)
Surface Temperature	-	+50°C
Weight	34 kg	30 kg
Painting	Colour RAL 7021	

Selection of Brake Size

Electo-hydraulic thruster is a device which develops liner thrust (or force) required to operate the required mechanism. The input to the device is three phase supply.

The brake torque must be => than motor full load as referred with drum. Formula as below:

$$T = \text{Torque in Kgm} = \frac{716 \times \text{Hp}}{\text{rpm}}$$

$$T = \text{Torque in Nm} = \frac{9552 \times \text{Kw}}{\text{rpm}}$$

Where Hp/Kw = motor output & rpm = Rev/minute

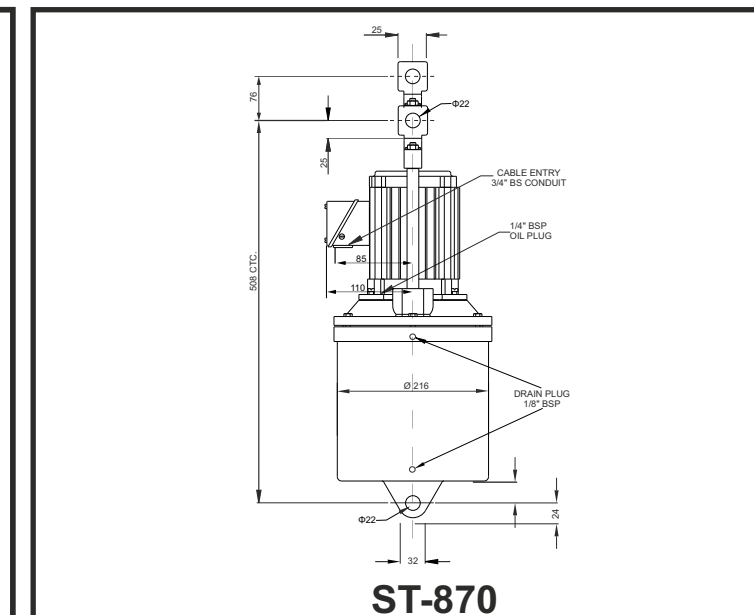
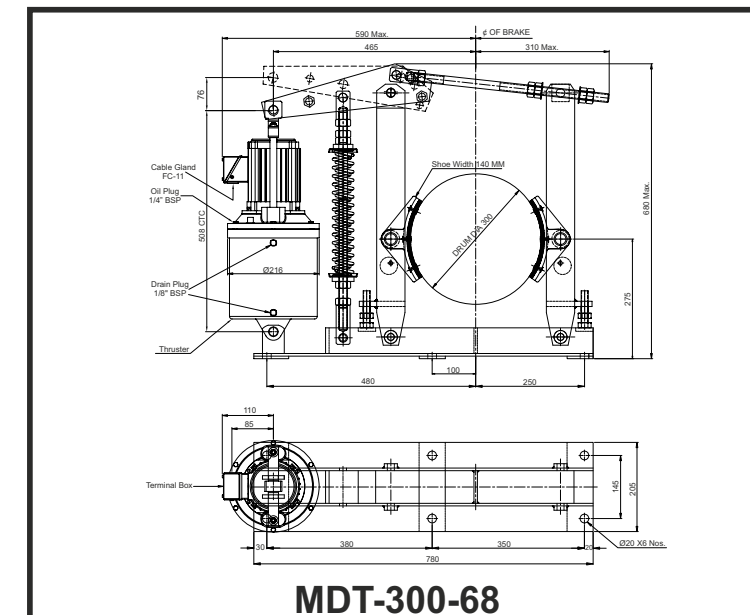

Multitech Systems

Plot No. 48-49, Gali No.6, Krishna Colony, Opp. Sector-25, Faridabad-121004, Haryana
E-mail : mtscranes@gmail.com | sales@multitechsystems.in
www.multitechsystem.net, 9910705767, 9911723747



9911417747
9560063747
9910043747
9911283747



Multitech Systems

Plot No. 48-49, Gali No.6, Krishna Colony, Opp. Sector-25, Faridabad-121004, Haryana
E-mail : mtscranes@gmail.com | sales@multitechsystems.in
www.multitechsystem.net, 9910705767, 9911723747



9911417747
9560063747
9910043747
9911283747

MDT 400-34

Mill Duty Thruster Brakes

INTRODUCTION

Thruster Brake is device to retard the speed of moving machinery and to stop it accurately to the desired position. The breaking force is applied to the brake shoes by a pre-stressed compression spring. The shoes press on the rotating brake drum retarding its speed, and finally stopping it.

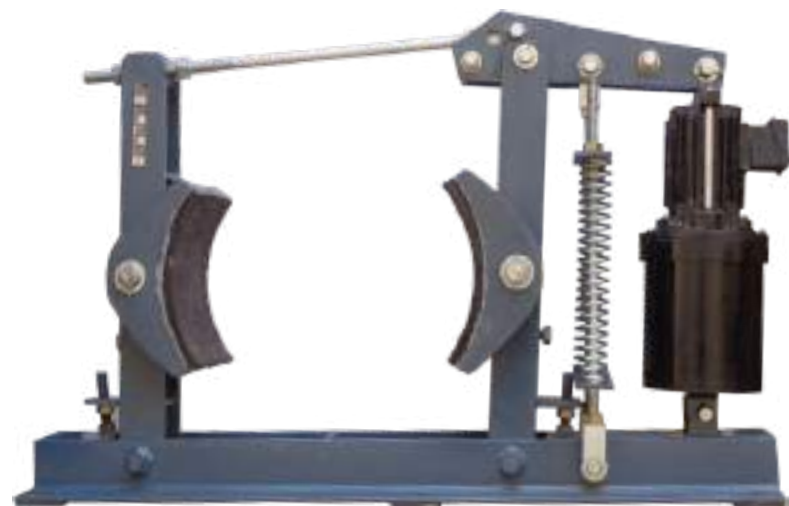

Technical Data

Item	Brake	Thruster
Model	MDT - 400-34	ST-535
Drum Dia	400 mm	-
Brake Shoe	Asbestos free/BA	-
Braking Torque	90 Kg-m	-
Thrust	-	34Kg
Stroke	-	51mm
Oil + Capacity	-	Transformer Oil 2.5 Litrs
Rated Voltage	-	415V±10%,3Ph AC,50Hz
Current At 415 V AC	-	0.5 Amps
Insulation	-	F Class
Ingress Protection	-	IP-44 IS/IEC 60529 (2001)
Surface Temperature	-	+50°C
Weight	54 kg	16 kg
Painting	Colour RAL 7021	

Selection of Brake Size

Electo-hydraulic thruster is a device which develops liner thrust (or force) required to operate the required mechanism. The input to the device is three phase supply.

The brake torque must be => than motor full load as referred with drum. Formula as below:

$$T = \text{Torque in Kgm} = \frac{716 \times \text{Hp}}{\text{rpm}}$$

$$T = \text{Torque in Nm} = \frac{9552 \times \text{Kw}}{\text{rpm}}$$

Where Hp/Kw = motor output & rpm = Rev/minute

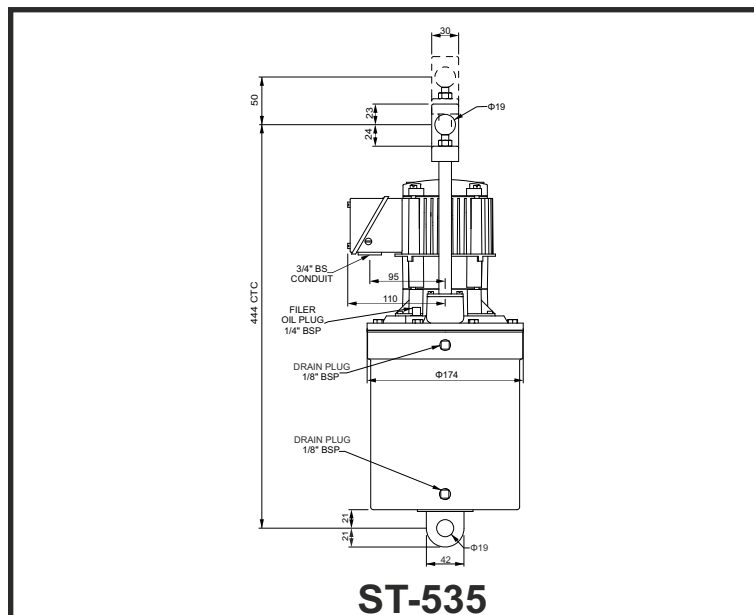
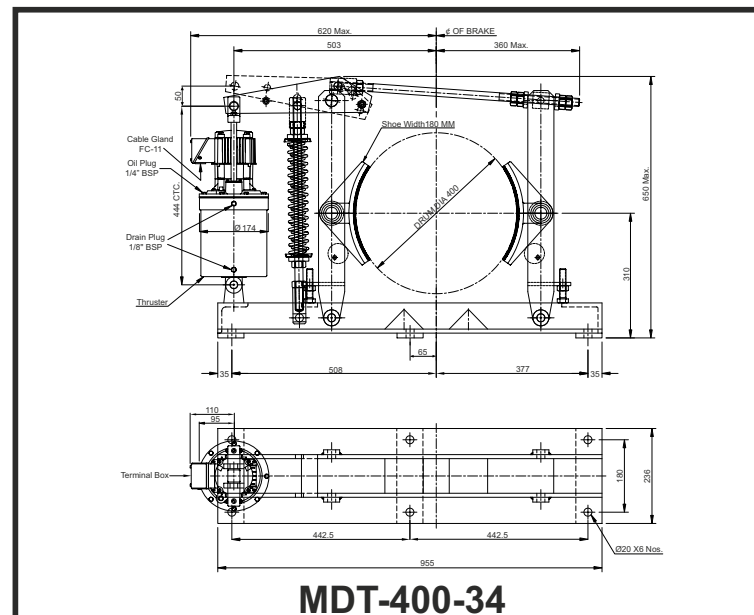

MDT 400-46

Mill Duty Thruster Brakes

INTRODUCTION

Thruster Brake is device to retard the speed of moving machinery and to stop it accurately to the desired position. The breaking force is applied to the brake shoes by a pre-stressed compression spring. The shoes press on the rotating brake drum retarding its speed, and finally stopping it.

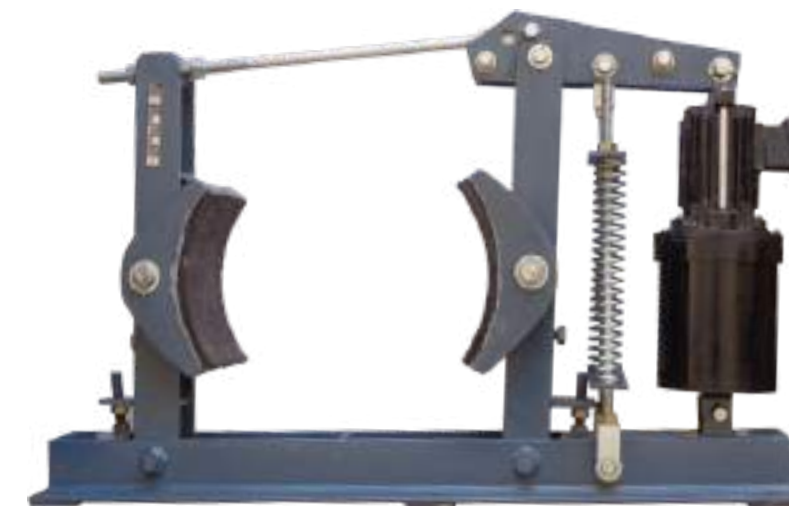

Technical Data

Item	Brake	Thruster
Model	MDT - 400-46	ST-545
Drum Dia	400 mm	-
Brake Shoe	Asbestos free/BA	-
Braking Torque	110 Kg-m	-
Thrust	-	46Kg
Stroke	-	51mm
Oil + Capacity	-	Transformer Oil 2.5 Litrs
Rated Voltage	-	415V±10%,3Ph AC,50Hz
Current At 415 V AC	-	0.6 Amps
Insulation	-	F Class
Ingress Protection	-	IP-55 IS/IEC 60529 (2001)
Surface Temperature	-	+50°C
Weight	56 kg	18 kg
Painting	Colour RAL 7021	

Selection of Brake Size

Electo-hydraulic thruster is a device which develops liner thrust (or force) required to operate the required mechanism. The input to the device is three phase supply.

The brake torque must be => than motor full load as referred with drum. Formula as below:

$$T = \text{Torque in Kgm} = \frac{716 \times \text{Hp}}{\text{rpm}}$$

$$T = \text{Torque in Nm} = \frac{9552 \times \text{Kw}}{\text{rpm}}$$

Where Hp/Kw = motor output & rpm = Rev/minute

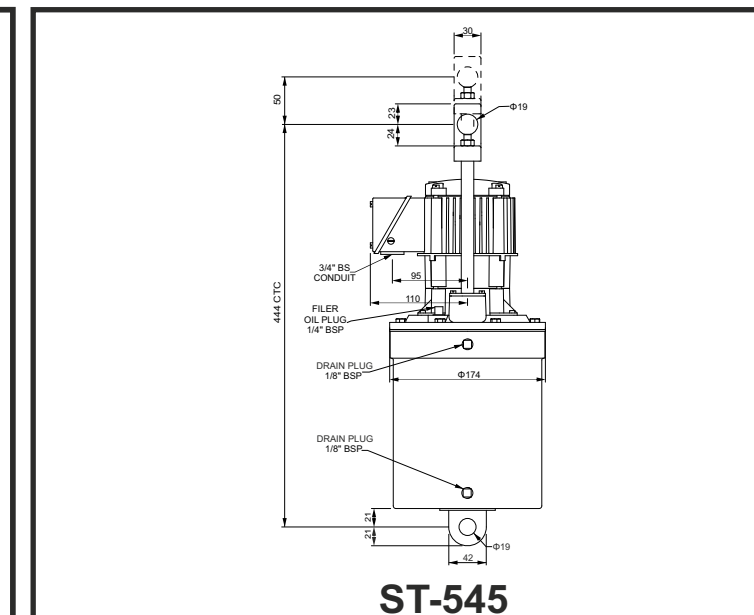
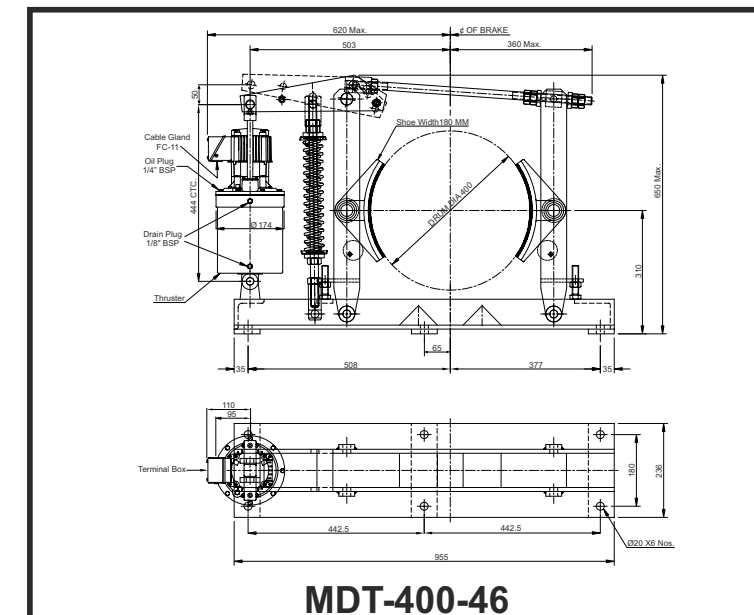

Multitech Systems

Plot No. 48-49, Gali No.6, Krishna Colony, Opp. Sector-25, Faridabad-121004, Haryana
E-mail : mtscranes@gmail.com | sales@multitechsystems.in
www.multitechsystem.net, 9910705767, 9911723747



9911417747
9560063747
9910043747
9911283747



Multitech Systems

Plot No. 48-49, Gali No.6, Krishna Colony, Opp. Sector-25, Faridabad-121004, Haryana
E-mail : mtscranes@gmail.com | sales@multitechsystems.in
www.multitechsystem.net, 9910705767, 9911723747



9911417747
9560063747
9910043747
9911283747

MDT 400-68

Mill Duty Thruster Brakes

INTRODUCTION

Thruster Brake is device to retard the speed of moving machinery and to stop it accurately to the desired position. The breaking force is applied to the brake shoes by a pre-stressed compression spring. The shoes press on the rotating brake drum retarding its speed, and finally stopping it.

Technical Data

Item	Brake	Thruster
Model	MDT - 400-68	ST-870
Drum Dia	400 mm	-
Brake Shoe	Asbestos free/BA	-
Braking Torque	170 Kg-m	-
Thrust	-	68Kg
Stroke	-	76mm
Oil + Capacity	-	Transformer Oil 4.5 Litrs
Rated Voltage	-	415V±10%,3Ph AC,50Hz
Current At 415 V AC	-	0.7 Amps
Insulation	-	F Class
Ingress Protection	-	IP-55 IS/IEC 60529 (2001)
Surface Temperature	-	+50°C
Weight	43 kg	30 kg
Painting	Colour RAL 7021	

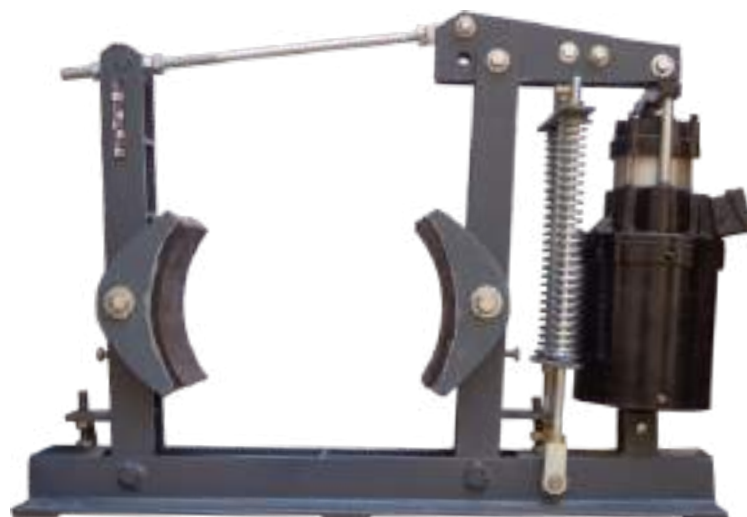

Selection of Brake Size

Electo-hydraulic thruster is a device which develops liner thrust (or force) required to operate the required mechanism. The input to the device is three phase supply.

The brake torque must be => than motor full load as referred with drum. Formula as below:

$$T = \text{Torque in Kgm} = \frac{716 \times \text{Hp}}{\text{rpm}}$$

$$T = \text{Torque in Nm} = \frac{9552 \times \text{Kw}}{\text{rpm}}$$

Where Hp/Kw = motor output & rpm = Rev/minute

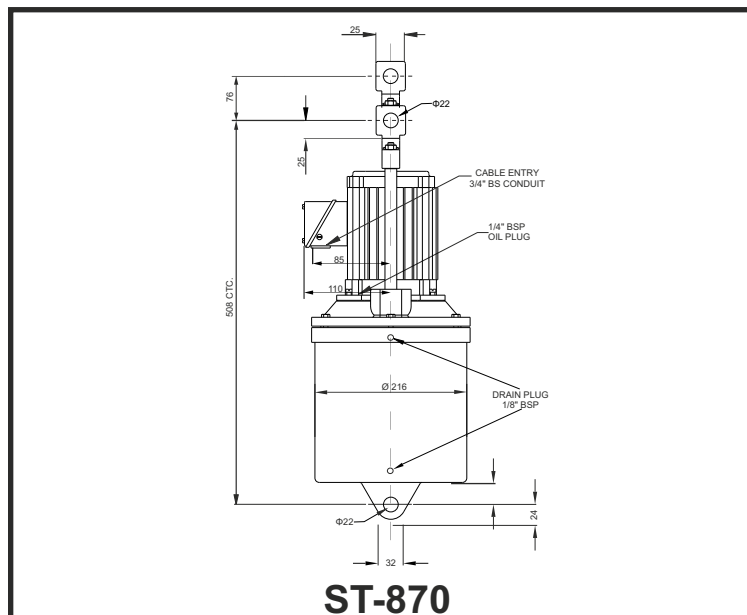
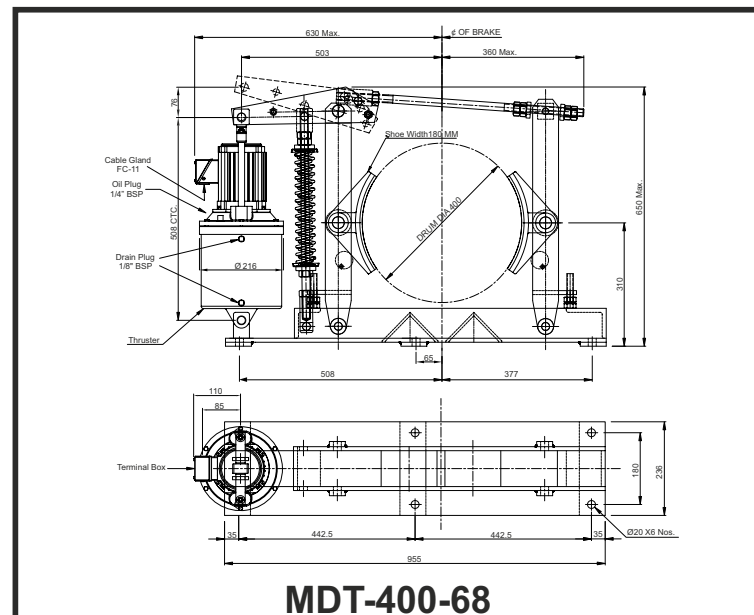

MDT 400-114

Mill Duty Thruster Brakes

INTRODUCTION

Thruster Brake is device to retard the speed of moving machinery and to stop it accurately to the desired position. The breaking force is applied to the brake shoes by a pre-stressed compression spring. The shoes press on the rotating brake drum retarding its speed, and finally stopping it.

Technical Data

Item	Brake	Thruster
Model	MDT - 400-114	ST-8110
Drum Dia	400 mm	-
Brake Shoe	Asbestos free/BA	-
Braking Torque	290 Kg-m	-
Thrust	-	114Kg
Stroke	-	76mm
Oil + Capacity	-	Transformer Oil 2.5 Litrs
Rated Voltage	-	415V±10%,3Ph AC,50Hz
Current At 415 V AC	-	0.8 Amps
Insulation	-	F Class
Ingress Protection	-	IP-55 IS/IEC 60529 (2001)
Surface Temperature	-	+50°C
Weight	43 kg	35 kg
Painting	Colour RAL 7021	

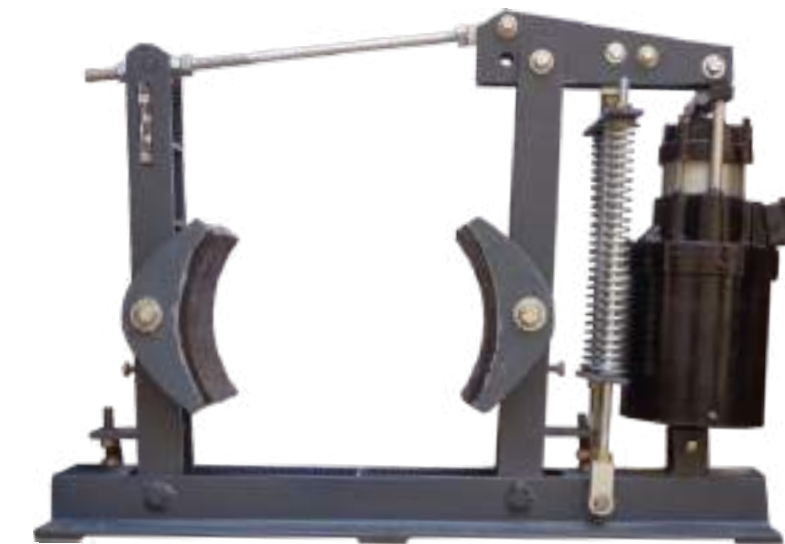

Selection of Brake Size

Electo-hydraulic thruster is a device which develops liner thrust (or force) required to operate the required mechanism. The input to the device is three phase supply.

The brake torque must be => than motor full load as referred with drum. Formula as below:

$$T = \text{Torque in Kgm} = \frac{716 \times \text{Hp}}{\text{rpm}}$$

$$T = \text{Torque in Nm} = \frac{9552 \times \text{Kw}}{\text{rpm}}$$

Where Hp/Kw = motor output & rpm = Rev/minute

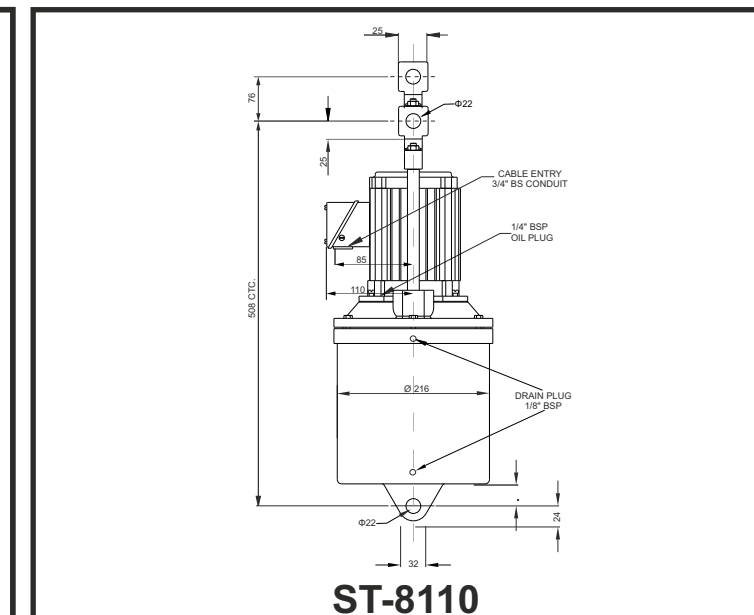
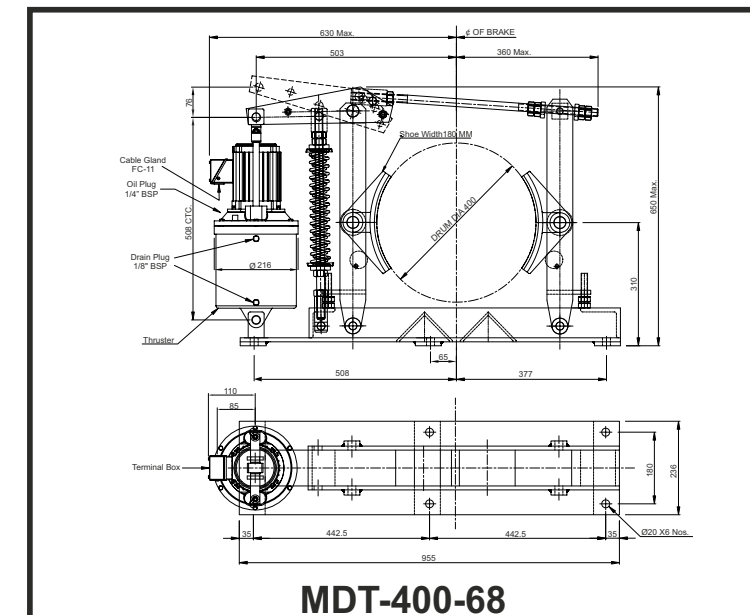

Multitech Systems

Plot No. 48-49, Gali No.6, Krishna Colony, Opp. Sector-25, Faridabad-121004, Haryana
 E-mail : mtscranes@gmail.com | sales@multitechsystems.in
www.multitechsystem.net, 9910705767, 9911723747



9911417747
 9560063747
 9910043747
 9911283747



Multitech Systems

Plot No. 48-49, Gali No.6, Krishna Colony, Opp. Sector-25, Faridabad-121004, Haryana
 E-mail : mtscranes@gmail.com | sales@multitechsystems.in
www.multitechsystem.net, 9910705767, 9911723747



9911417747
 9560063747
 9910043747
 9911283747

MDT 500-34

Mill Duty Thruster Brakes

INTRODUCTION

Thruster Brake is device to retard the speed of moving machinery and to stop it accurately to the desired position. The breaking force is applied to the brake shoes by a pre-stressed compression spring. The shoes press on the rotating brake drum retarding its speed, and finally stopping it.

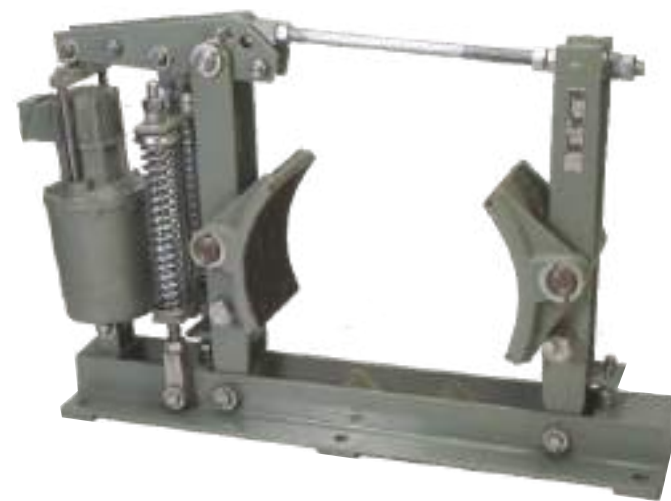

Technical Data

Item	Brake	Thruster
Model	MDT - 500-34	ST-535
Drum Dia	500 mm	-
Brake Shoe	Asbestos free/BA	-
Braking Torque	110 Kg-m	-
Thrust	-	35Kg
Stroke	-	51mm
Oil + Capacity	-	Transformer Oil 2.5 Litrs
Rated Voltage	-	415V±10%,3Ph AC,50Hz
Current At 415 V AC	-	0.5 Amps
Insulation	-	F Class
Ingress Protection	-	IP-55 IS/IEC 60529 (2001)
Surface Temperature	-	+50°C
Weight	90 kg	16 kg
Painting	Colour RAL 7021	

Selection of Brake Size

Electo-hydraulic thruster is a device which develops liner thrust (or force) required to operate the required mechanism. The input to the device is three phase supply.

The brake torque must be => than motor full load as referred with drum. Formula as below:

$$T = \text{Torque in Kgm} = \frac{716 \times \text{Hp}}{\text{rpm}}$$

$$T = \text{Torque in Nm} = \frac{9552 \times \text{Kw}}{\text{rpm}}$$

Where Hp/Kw = motor output & rpm = Rev/minute

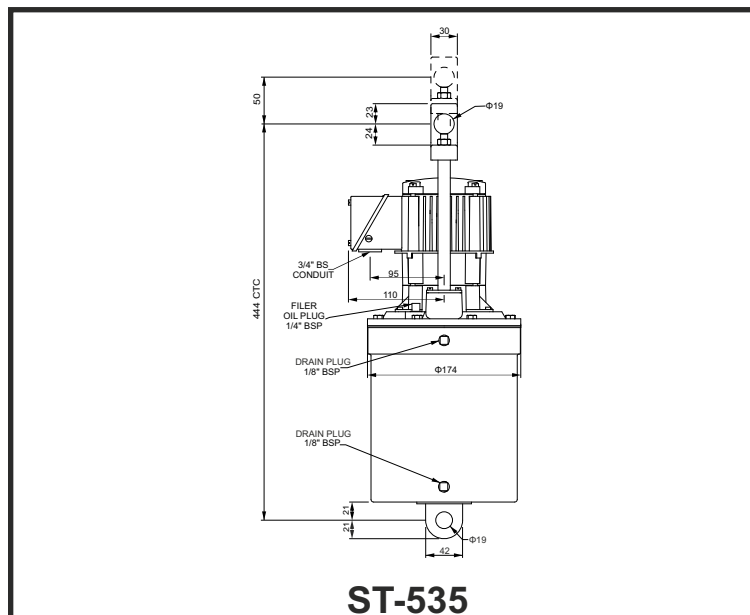
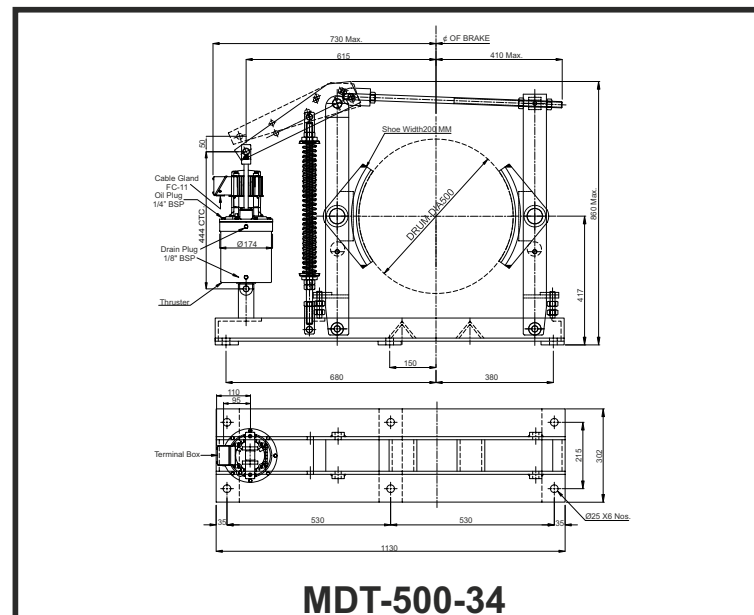

MDT 500-46

Mill Duty Thruster Brakes

INTRODUCTION

Thruster Brake is device to retard the speed of moving machinery and to stop it accurately to the desired position. The breaking force is applied to the brake shoes by a pre-stressed compression spring. The shoes press on the rotating brake drum retarding its speed, and finally stopping it.

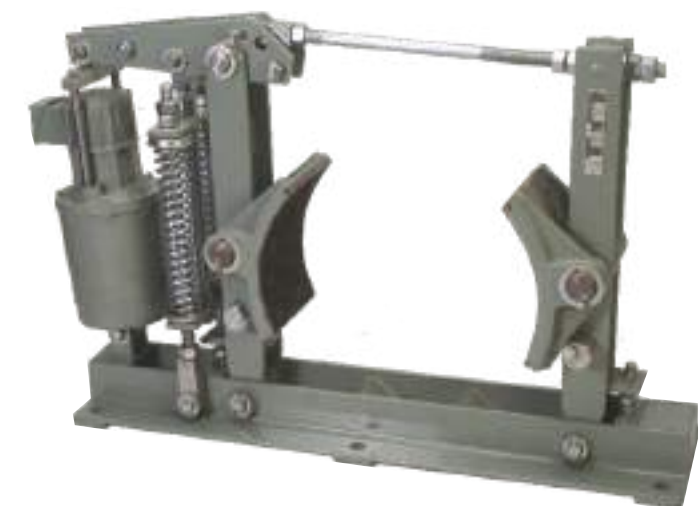

Technical Data

Item	Brake	Thruster
Model	MDT - 500-46	ST-545
Drum Dia	500 mm	-
Brake Shoe	Asbestos free/BA	-
Braking Torque	190 Kg-m	-
Thrust	-	46Kg
Stroke	-	51mm
Oil + Capacity	-	Transformer Oil 4.5 Litrs
Rated Voltage	-	415V±10%,3Ph AC,50Hz
Current At 415 V AC	-	0.6 Amps
Insulation	-	F Class
Ingress Protection	-	IP-55 IS/IEC 60529 (2001)
Surface Temperature	-	+50°C
Weight	62 kg	18 kg
Painting	Colour RAL 7021	

Selection of Brake Size

Electo-hydraulic thruster is a device which develops liner thrust (or force) required to operate the required mechanism. The input to the device is three phase supply.

The brake torque must be => than motor full load as referred with drum. Formula as below:

$$T = \text{Torque in Kgm} = \frac{716 \times \text{Hp}}{\text{rpm}}$$

$$T = \text{Torque in Nm} = \frac{9552 \times \text{Kw}}{\text{rpm}}$$

Where Hp/Kw = motor output & rpm = Rev/minute

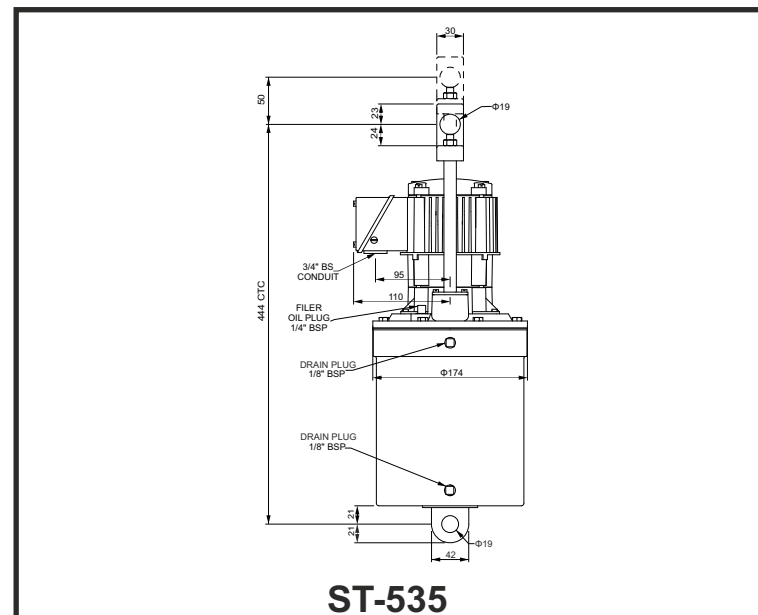
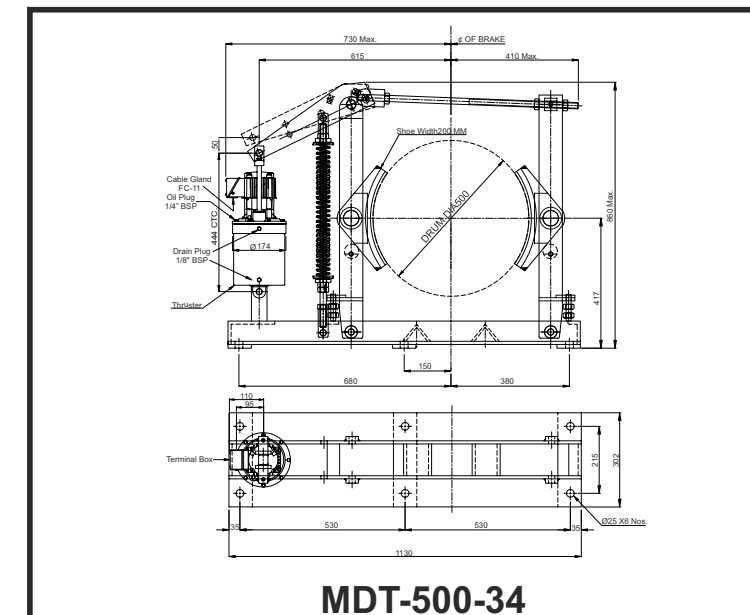

Multitech Systems

Plot No. 48-49, Gali No.6, Krishna Colony, Opp. Sector-25, Faridabad-121004, Haryana
E-mail : mtscranes@gmail.com | sales@multitechsystems.in
www.multitechsystem.net, 9910705767, 9911723747



9911417747
9560063747
9910043747
9911283747



Multitech Systems

Plot No. 48-49, Gali No.6, Krishna Colony, Opp. Sector-25, Faridabad-121004, Haryana
E-mail : mtscranes@gmail.com | sales@multitechsystems.in
www.multitechsystem.net, 9910705767, 9911723747



9911417747
9560063747
9910043747
9911283747

MDT 500-68

Mill Duty Thruster Brakes

INTRODUCTION

Thruster Brake is device to retard the speed of moving machinery and to stop it accurately to the desired position. The breaking force is applied to the brake shoes by a pre-stressed compression spring. The shoes press on the rotating brake drum retarding its speed, and finally stopping it.



Technical Data

Item	Brake	Thruster
Model	MDT - 500-68	ST-870
Drum Dia	500 mm	-
Brake Shoe	Asbestos free/BA	-
Braking Torque	290 Kg-m	-
Thrust	-	68Kg
Stroke	-	76mm
Oil + Capacity	-	Transformer Oil 2.5 Litrs
Rated Voltage	-	415V±10%,3Ph AC,50Hz
Current At 415 V AC	-	0.7 Amps
Insulation	-	F Class
Ingress Protection	-	IP-55 IS/IEC 60529 (2001)
Surface Temperature	-	+50°C
Weight	60 kg	30 kg
Painting	Colour RAL 7021	

Selection of Brake Size

Electo-hydraulic thruster is a device which develops liner thrust (or force) required to operate the required mechanism. The input to the device is three phase supply.

The brake torque must be => than motor full load as referred with drum. Formula as below:

$$T = \text{Torque in Kgm} = \frac{716 \times \text{Hp}}{\text{rpm}}$$

$$T = \text{Torque in Nm} = \frac{9552 \times \text{Kw}}{\text{rpm}}$$

Where Hp/Kw = motor output & rpm = Rev/minute

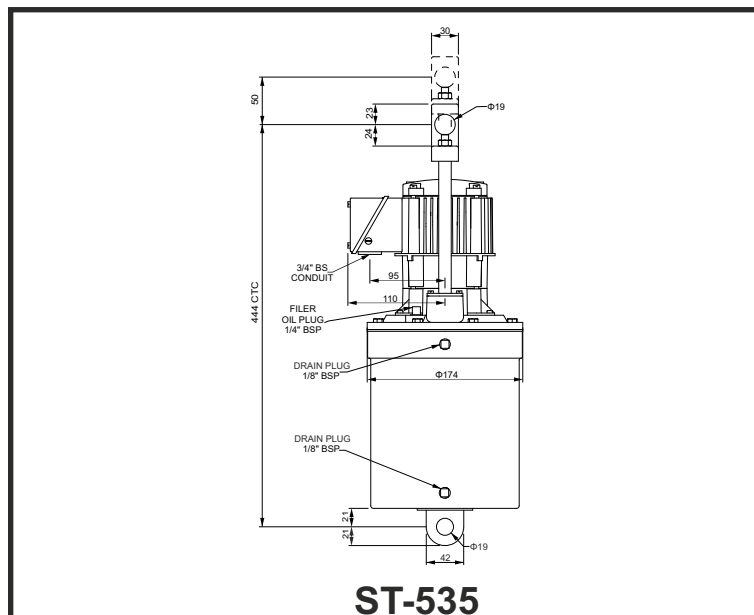
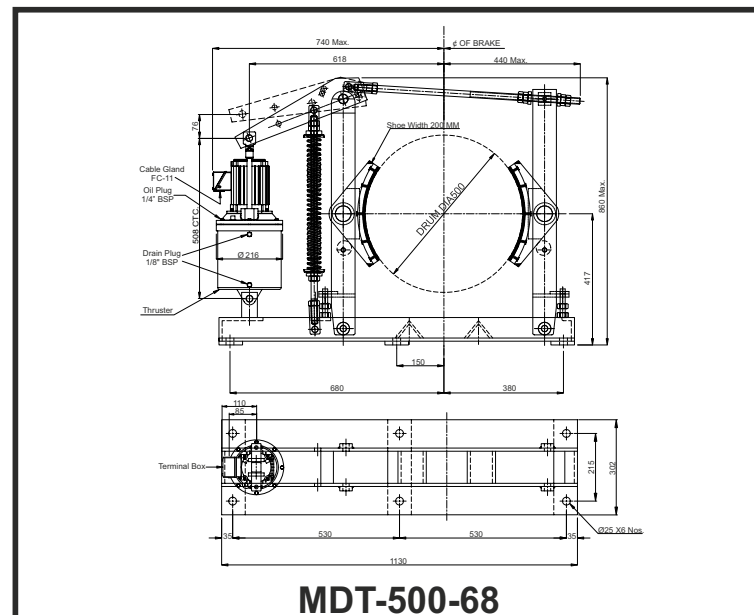

MDT 500-114

Mill Duty Thruster Brakes

INTRODUCTION

Thruster Brake is device to retard the speed of moving machinery and to stop it accurately to the desired position. The breaking force is applied to the brake shoes by a pre-stressed compression spring. The shoes press on the rotating brake drum retarding its speed, and finally stopping it.



Technical Data

Item	Brake	Thruster
Model	MDT - 500-114	ST-8110
Drum Dia	500 mm	-
Brake Shoe	Asbestos free/BA	-
Braking Torque	485 Kg-m	-
Thrust	-	114Kg
Stroke	-	76mm
Oil + Capacity	-	Transformer Oil 4.5 Litrs
Rated Voltage	-	415V±10%,3Ph AC,50Hz
Current At 415 V AC	-	0.8 Amps
Insulation	-	F Class
Ingress Protection	-	IP-55 IS/IEC 60529 (2001)
Surface Temperature	-	+50°C
Weight	75 kg	35 kg
Painting	Colour RAL 7021	

Selection of Brake Size

Electo-hydraulic thruster is a device which develops liner thrust (or force) required to operate the required mechanism. The input to the device is three phase supply.

The brake torque must be => than motor full load as referred with drum. Formula as below:

$$T = \text{Torque in Kgm} = \frac{716 \times \text{Hp}}{\text{rpm}}$$

$$T = \text{Torque in Nm} = \frac{9552 \times \text{Kw}}{\text{rpm}}$$

Where Hp/Kw = motor output & rpm = Rev/minute

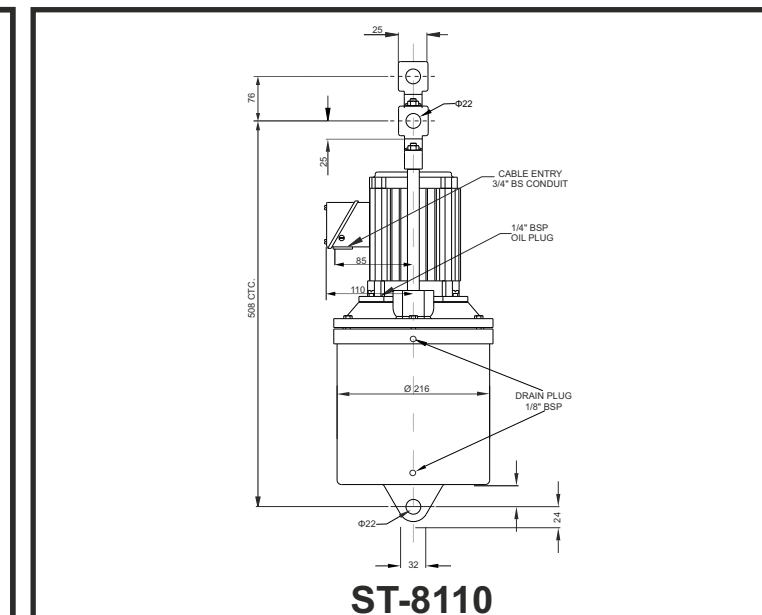
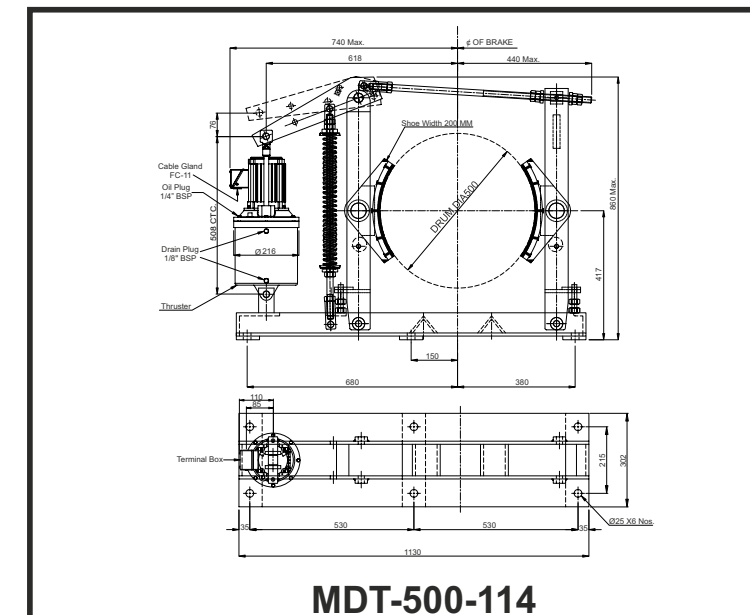

Multitech Systems

Plot No. 48-49, Gali No.6, Krishna Colony, Opp. Sector-25, Faridabad-121004, Haryana
 E-mail : mtscranes@gmail.com | sales@multitechsystems.in
www.multitechsystem.net, 9910705767, 9911723747



9911417747
 9560063747
 9910043747
 9911283747



Multitech Systems

Plot No. 48-49, Gali No.6, Krishna Colony, Opp. Sector-25, Faridabad-121004, Haryana
 E-mail : mtscranes@gmail.com | sales@multitechsystems.in
www.multitechsystem.net, 9910705767, 9911723747



9911417747
 9560063747
 9910043747
 9911283747

Lever Type Limit Switch 10A

INTRODUCTION

Lever Type Limit Switch operates the control change-over contacts of motor of an moving equipments when a cam moving with loads actuates the lever of Limit Switch. This turns the cam on a square shaft and operate the NO/NC change over contact elements.

Technical Data

Body Material	Alluminium Die Cast (Powder Coated)
Protection Degree	IP-55 Confirming to (IS/IEC-60529(2001)
Mounting Position	Floor
Cable Entries	2, 3/4" Conduit
No. Of Contacts	MAX 2
Contact Material	Silver Cadmium
Wire Connection	Screw Terminal
Rated voltage	500 V.A.C. Max
Thermal Test Current	10 A



Lever Type Limit Switch 40A

INTRODUCTION

Lever Type Limit Switch operates the control change-over contacts of motor of an moving equipments when a cam moving with loads actuates the lever of Limit Switch. This turns the cam on a square shaft and operate the NO/NC change over contact elements.

Technical Data

Body Material	Alluminium Die Cast (Powder Coated)
Protection Degree	IP-55 Confirming to (IS/IEC-60529(2001)
Mounting Position	Floor
Cable Entries	2, 3/4" Conduit
No. Of Contacts	MAX 4
Contact Material	Silver Cadmium
Wire Connection	Screw Terminal
Rated voltage	500 V.A.C. Max
Thermal Test Current	40 A



SWITCHING DIAGRAM

LS/1SH/1(ONE WAY)
901300010001

CONTACT NO.	1	0
1	X	X

LS/1SH/2(ONE WAY)
901300010002

CONTACT NO.	1	0
1	X	X
2	X	X

LS/2SH/2(TWO WAY)
901300010003

CONTACT NO.	1	0	1
1	X	X	X
2	X	X	X

Lever Limit Switch (Downward Lever)

Lever Limit Switch (Upward Lever)

SWITCHING DIAGRAM

LS/1SH/1(ONE WAY)
901300020001

CONTACT NO.	1	0
1	X	X

LS/1SH/2(ONE WAY)
901300020002

CONTACT NO.	1	0
1	X	X
2	X	X

LS/2SH/2(TWO WAY)
901300020003

CONTACT NO.	1	0	1
1	X	X	X
2	X	X	X

LS/2SH/4(TWO WAY)
901300020005

CONTACT NO.	2	1	0	1	2
1	X	X	X	X	X
2	X	X	X	X	X
3	X	X	X	X	X
4	X	X	X	X	X

Lever Limit Switch (Downward Lever)

Lever Limit Switch (Upward Lever)



Multitech Systems

Plot No. 48-49, Gali No.6, Krishna Colony, Opp. Sector-25, Faridabad-121004, Haryana
E-mail : mtscranes@gmail.com | sales@multitechsystems.in
www.multitechsystem.net, 9910705767, 9911723747



9911417747
9560063747
9910043747
9911283747



Multitech Systems

Plot No. 48-49, Gali No.6, Krishna Colony, Opp. Sector-25, Faridabad-121004, Haryana
E-mail : mtscranes@gmail.com | sales@multitechsystems.in
www.multitechsystem.net, 9910705767, 9911723747



9911417747
9560063747
9910043747
9911283747

Geared Rotary Limit Switch GRLS/48/2SH

INTRODUCTION

Rotary Geared Limit Switch GRLS is used to trip Motor Supply when the moving loads reach the extreme end positions of working zone. The driving motion is transmitted by worm gear through worm shaft. The rotations & movements are transmitted to switches by adjustable cams. Complying to IEC/EN 60947-5-1, IEC/EN 60529, IES 60060-2-78 IES 60068-2-30.

Application

A Rotary Geared Limit Switch Are Suitable For Use On Reversing Drives Such As Hoists, Winches Rolling Mills & Various Other Mechanisms Used In Steel Plants Such As Coke Oven, Feeding Oven Machinery Etc.



Mechanical Data

Ratio	Effective Rotations	Useful Rotations	2 Contacts Model
48:1	48	40	GRLS/48/2SH

Technical Data :

Body Material	Aluminium Die Cast
Protection Degree	IP-55 Confirming to (IS/IEC : 60529(2001))
Gear Ratio	48:1
Drive	Worm Drive
Cable Entries	2x3/4" Conduit
Contact Material	Silver Cadmium
Rated Voltage Insulation	500 V.A.C.
Thermal Test Current	40 Amps
No. Of Contacts	2NC OR 2NO
Cam Setting	Adjustable

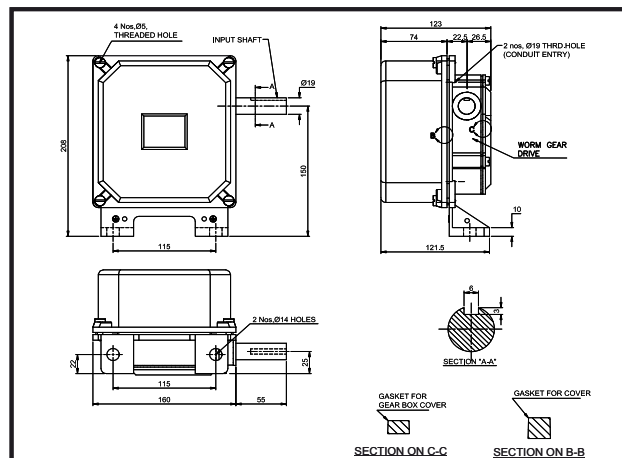

GRLS/48/2SH

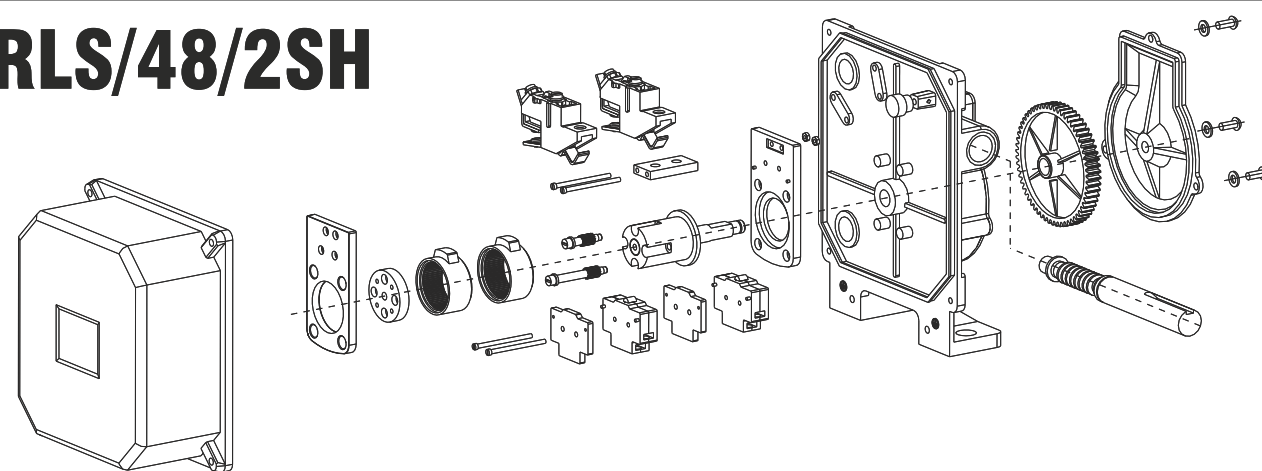

Geared Rotary Limit Switch GRLS/48/4SH

INTRODUCTION

Rotary Geared Limit Switch GRLS is used to trip Motor Supply when the moving loads reach the extreme end positions of working zone. The driving motion is transmitted by worm gear through worm shaft. The rotations & movements are transmitted to switches by adjustable cams. Complying to IEC/EN 60947-5-1, IEC/EN 60529, IES 60060-2-78 IES 60068-2-30.

Application

A Rotary Geared Limit Switch Are Suitable For Use On Reversing Drives Such As Hoists, Winches Rolling Mills & Various Other Mechanisms Used In Steel Plants Such As Coke Oven, Feeding Oven Machinery Etc.



Mechanical Data

Ratio	Effective Rotations	Useful Rotations	2 Contacts Model
48:1	48	40	GRLS/48/4SH

Technical Data :

Body Material	Aluminium Die Cast
Protection Degree	IP-65 Confirming to (IS/IEC : 60529(2001))
Gear Ratio	48:1
Drive	Worm Drive
Cable Entries	2x3/4" Conduit
Contact Material	Silver Cadmium
Rated Voltage Insulation	500 V.A.C.
Thermal Test Current	40 Amps
No. Of Contacts	4NC OR 4NO
Cam Setting	Adjustable

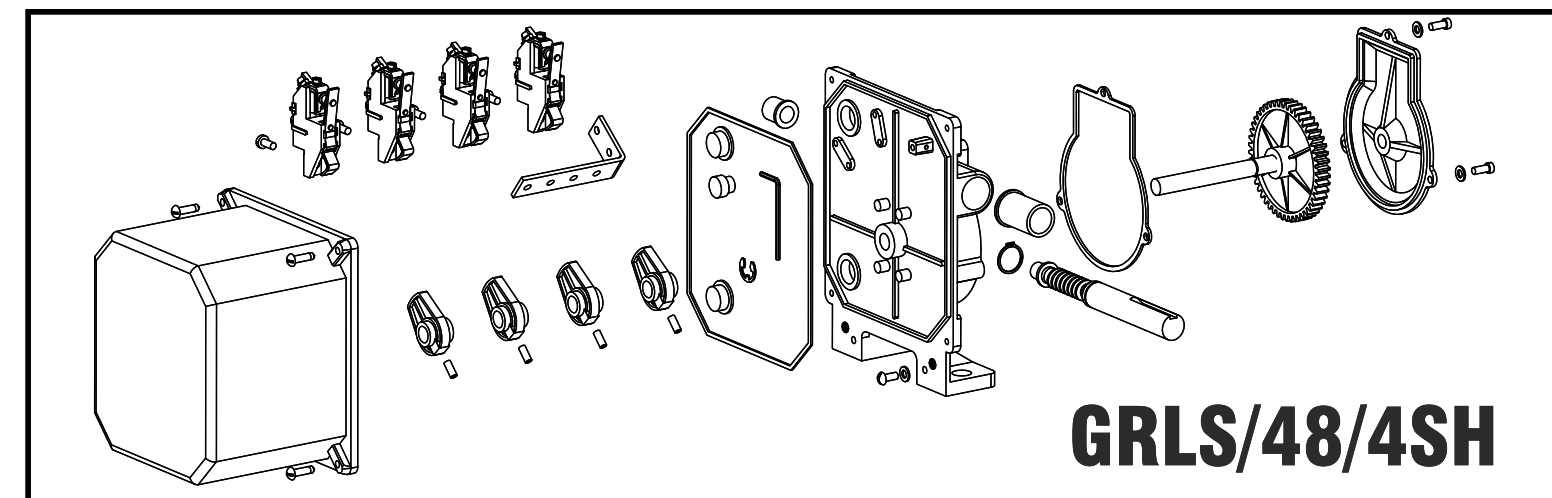
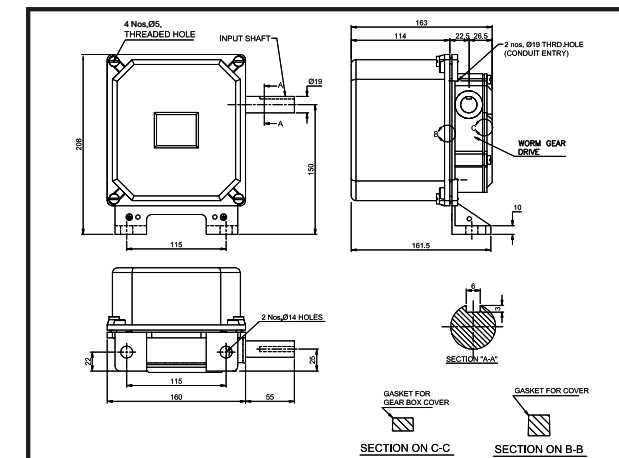

GRLS/48/4SH



Multitech Systems

Plot No. 48-49, Gali No.6, Krishna Colony, Opp. Sector-25, Faridabad-121004, Haryana
E-mail : mtscranes@gmail.com | sales@multitechsystems.in
www.multitechsystem.net, 9910705767, 9911723747



9911417747
9560063747
9910043747
9911283747



Multitech Systems

Plot No. 48-49, Gali No.6, Krishna Colony, Opp. Sector-25, Faridabad-121004, Haryana
E-mail : mtscranes@gmail.com | sales@multitechsystems.in
www.multitechsystem.net, 9910705767, 9911723747



9911417747
9560063747
9910043747
9911283747

Geared Rotary Limit Switch

GRLS/60/2SH

INTRODUCTION

Rotary Geared Limit Switch GRLS is used to trip Motor Supply when the moving loads reach the extreme end positions of working zone. The driving motion is transmitted by worm gear through worm shaft. The rotations & movements are transmitted to switches by adjustable cams. Complying to IEC/EN 60947-5-1, IEC/EN 60529, IES 60060-2-78 IES 60068-2-30.

Application

A Rotary Geared Limit Switch Are Suitable For Use On Reversing Drives Such As Hoists, Winches Rolling Mills & Various Other Mechanisms Used In Steel Plants Such As Coke Oven, Feeding Oven Machinery Etc.



Mechanical Data

Ratio	Effective Rotations	Useful Rotations	2 Contacts Model
60:1	60	52	GRLS/60/2SH

Technical Data :

Body Material	Aluminium Die Cast
Protection Degree	IP-55 Confirming to (IS/IEC : 60529(2001))
Gear Ratio	60:1
Drive	Worm Drive
Cable Entries	2x3/4" Conduit
Contact Material	Silver Cadmium
Rated Voltage Insulation	500 V.A.C.
Thermal Test Current	40 Amps
No. Of Contacts	2NC OR 2NO
Cam Setting	Adjustable

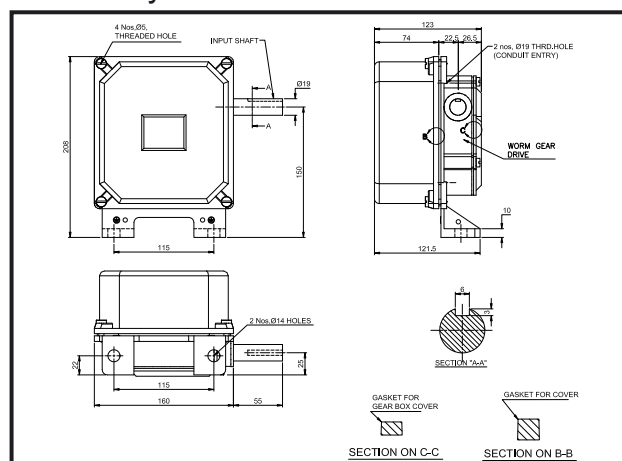

GRLS/60/2SH

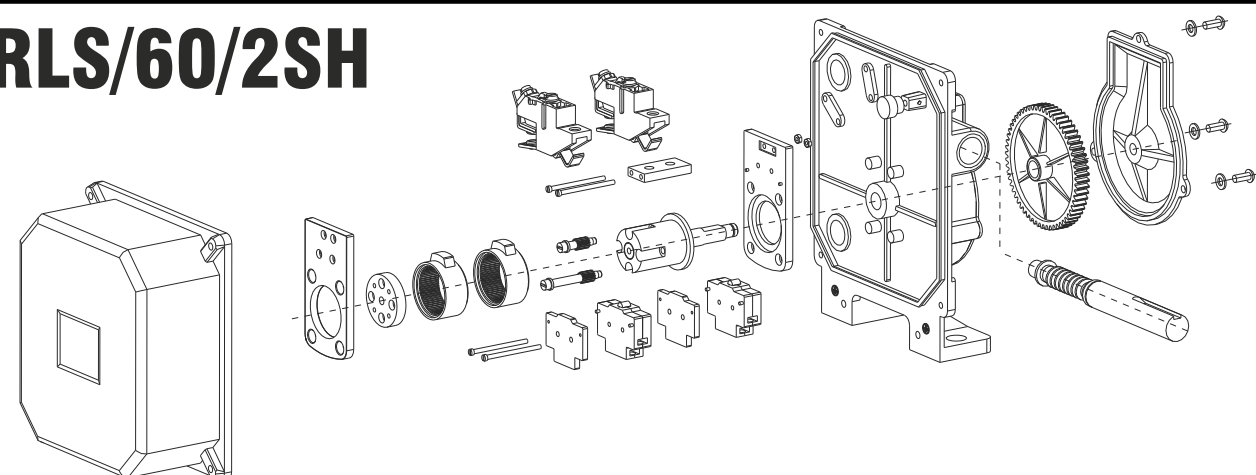

Multitech Systems

Plot No. 48-49, Gali No.6, Krishna Colony, Opp. Sector-25, Faridabad-121004, Haryana
E-mail : mtscranes@gmail.com | sales@multitechsystems.in
www.multitechsystem.net, 9910705767, 9911723747



9911417747
9560063747
9910043747
9911283747

Geared Rotary Limit Switch

GRLS/96/2SH

INTRODUCTION

Rotary Geared Limit Switch GRLS is used to trip Motor Supply when the moving loads reach the extreme end positions of working zone. The driving motion is transmitted by worm gear through worm shaft. The rotations & movements are transmitted to switches by adjustable cams. Complying to IEC/EN 60947-5-1, IEC/EN 60529, IES 60060-2-78 IES 60068-2-30.

Application

A Rotary Geared Limit Switch Are Suitable For Use On Reversing Drives Such As Hoists, Winches Rolling Mills & Various Other Mechanisms Used In Steel Plants Such As Coke Oven, Feeding Oven Machinery Etc.



Mechanical Data

Ratio	Effective Rotations	Useful Rotations	2 Contacts Model
96:1	96	84	GRLS/96/2SH

Technical Data :

Body Material	Aluminium Die Cast
Protection Degree	IP-55 Confirming to (IS/IEC : 60529(2001))
Gear Ratio	96:1
Drive	Worm Drive
Cable Entries	2x3/4" Conduit
Contact Material	Silver Cadmium
Rated Voltage Insulation	500 V.A.C.
Thermal Test Current	40 Amps
No. Of Contacts	2NC OR 4NO
Cam Setting	Adjustable

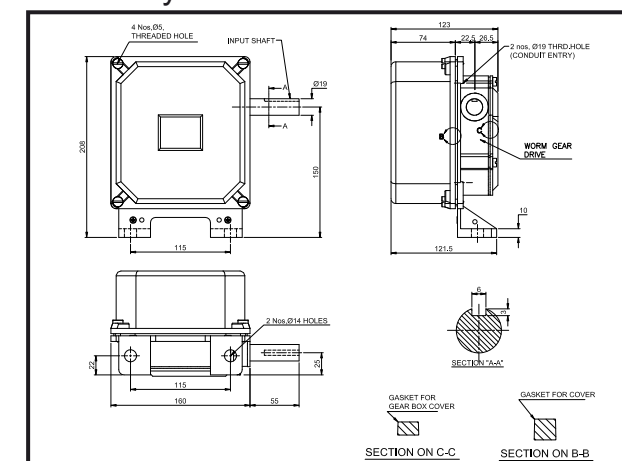

GRLS/96/2SH

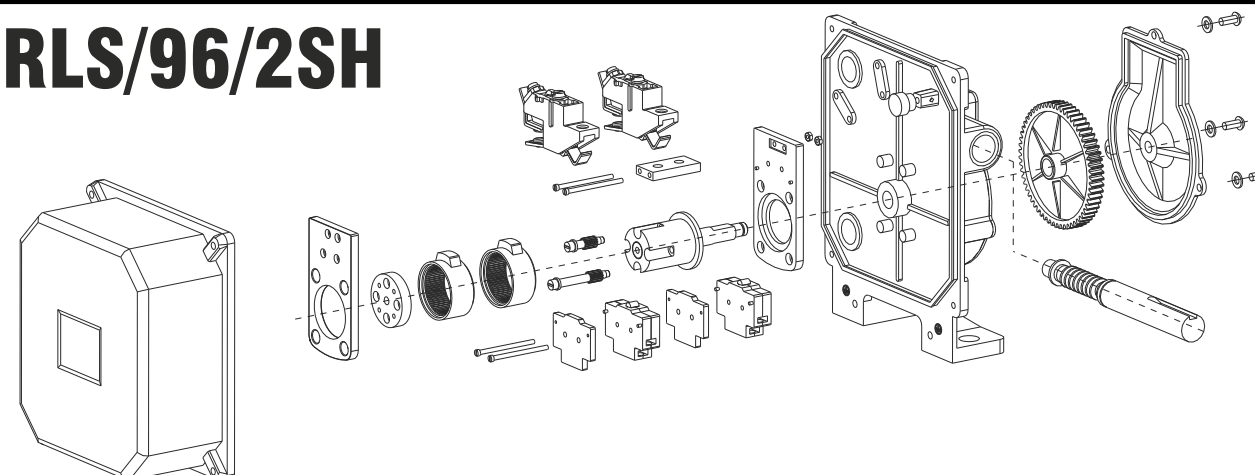

Multitech Systems

Plot No. 48-49, Gali No.6, Krishna Colony, Opp. Sector-25, Faridabad-121004, Haryana
E-mail : mtscranes@gmail.com | sales@multitechsystems.in
www.multitechsystem.net, 9910705767, 9911723747



9911417747
9560063747
9910043747
9911283747

Counter Weight Limit Switch 40A

INTRODUCTION

Weight Operated Limit Switches are used on control/ power circuit of reversing drives so as to limit their rotation / movement with in a predetermined position. Complying to IEC/EN 60947-5-1, IEC/EN 60529, IEC 60068-2-78, IEC 60068-2-30

Operation

When the snatch block of the crane reaches its top position the snatch block pushes a plate which is hanging from one end of the lever of the limit switch. Due to the weight placed on the other end of the lever this lever is pushed up. When the lever is pushed up by the shaft to which this lever is connected rotates there by rotating the cams which eventually open the contacts



Switching Diagram

CWLS/1SH/1
101400020001

CONTACT NO.	0	1
1	X	

CWLS/1SH/2
101400020002

CONTACT NO.	0	1
1	X	
2	X	

CWLS/1SH/11
101400020003

CONTACT NO.	0	1
1	X	
2		X

Technical Data

Body material	Powder coated, Aluminium Die cast
Degree of protection	IP-55 IS/IEC-600529 : 2001
Mounting position	Floor Mounting
Cable Entries	Twin, 3/4" BS conduit
No. of contact	2
Contact	Silver-cadmium
Wire connection	Screwed Terminals
Thermal Test Current	40 A
Rated Voltage	500 VAC

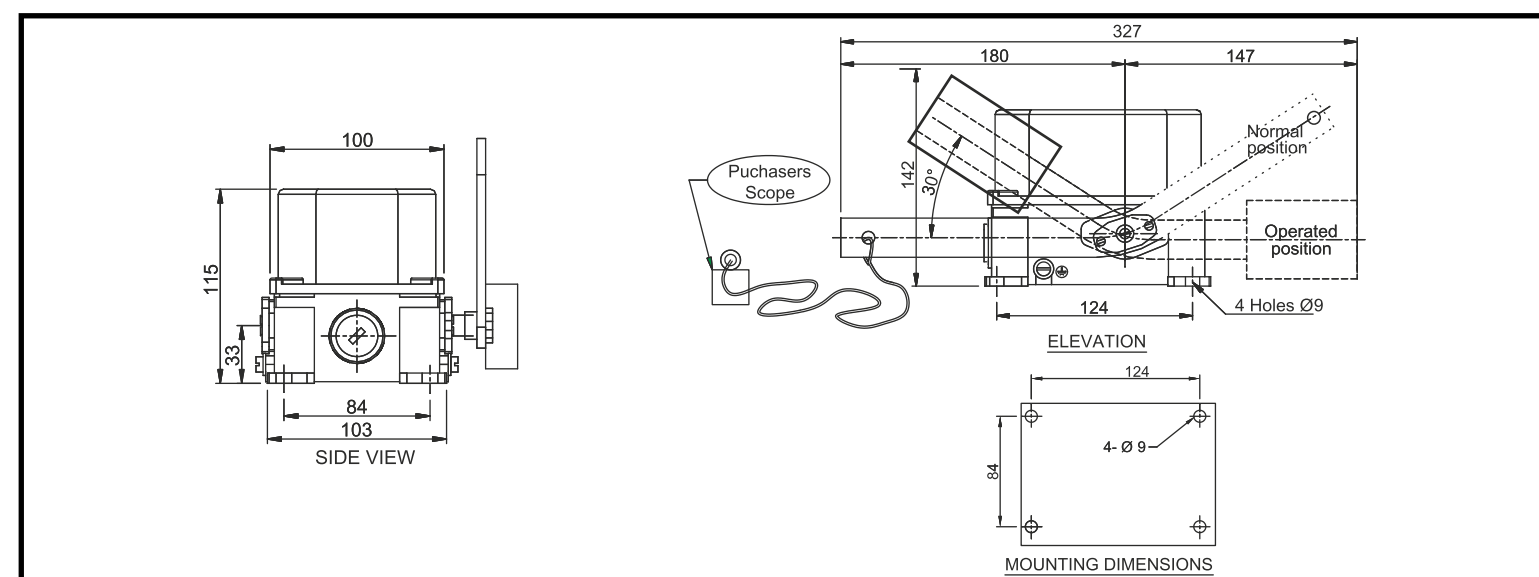

Anti-Collision Limit Switch

INTRODUCTION

The anti-collision system is a safety device to avoid collision of two electric overhead travelling cranes on the same bay. The system works on the principle of retro-reflective infrared waves.

The system comprises of an emitter cum receiver module and a reflector. The emitter continuously emits infrared waves into the direction of the reflector. The waves are reflected back to the receiver end of the system which activates an alarm signal to an stops/reduce the speed of the crane. If two cranes are away from each other the reflected waves will not reach the sensor and the cranes operate normally.

The advanced digital anti-collision system incorporates a Micro-Controller Based Circuit for taking digital inputs for easy range setting and gives an accurate cut-off range to the device. Two sets of anti-collision systems are required for collision avoidance between the two cranes.

Technical Specifications:

Micro Controller Based System (MTSACD 0-10)	
Supply Voltage	110VAC - 220VAC
Operating Temperature	Upto 70C
Output	Upto 2 Potential free relays
Sensing Distance (adjustable)	1 - 3 / 3 - 10 meters

Installation Procedure:

1. Mount the Transmitter/Emitter(Control Unit) on one crane as shown in installation scheme.
2. Connect the power supply as per the connection diagram.
3. Press the laser switch and mark the point for reflector mounting. Mount the reflector on the second crane.
4. Similarly follow the procedure to mount the control unit and reflector for the other crane.
5. Connect the relay output as shown in the figure. The Anti-collision device works like an LT limit switch.

Range Adjustment Setting:

1. Make sure the system is powered off.
2. For Relay 1, keeping Inc key pressed, power on the system For Relay 2, keeping the Shift key pressed, power on the system. The display should show SET/(r11) or SET/(r12), then show digit (d00).
3. Using the Inc. key, set the number to the distance at which the relay should cut-off.
4. After selecting the range, press the Set key.
5. Restart the system.

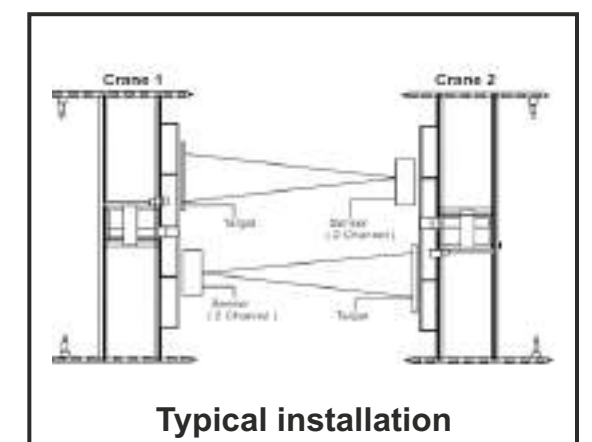
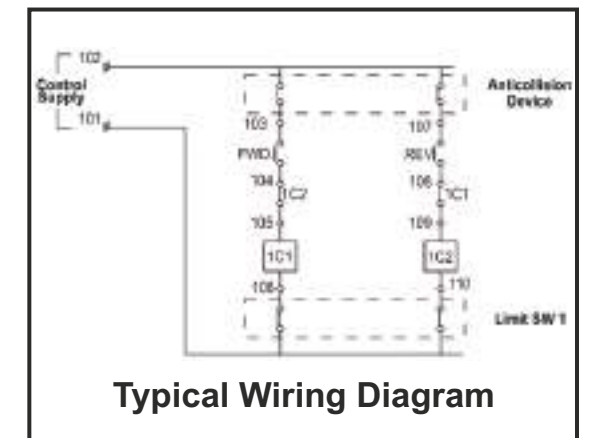
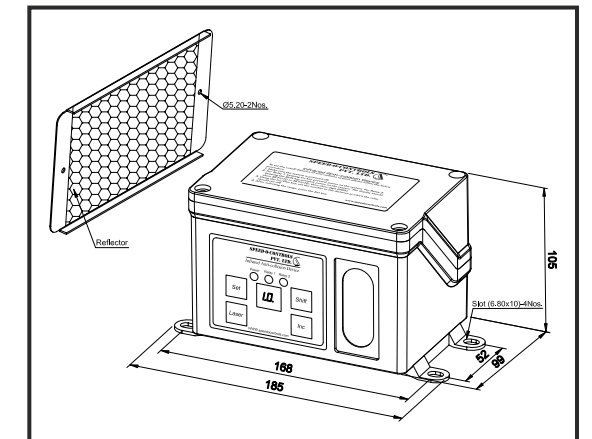

Multitech Systems

Plot No. 48-49, Gali No.6, Krishna Colony, Opp. Sector-25, Faridabad-121004, Haryana
E-mail : mtscranes@gmail.com | sales@multitechsystems.in
www.multitechsystem.net, 9910705767, 9911723747



9911417747
9560063747
9910043747
9911283747



Multitech Systems

Plot No. 48-49, Gali No.6, Krishna Colony, Opp. Sector-25, Faridabad-121004, Haryana
E-mail : mtscranes@gmail.com | sales@multitechsystems.in
www.multitechsystem.net, 9910705767, 9911723747



9911417747
9560063747
9910043747
9911283747

Master Controller(IP-41)

INTRODUCTION

Master Controller Is Housed In Enclosure And Provided With An Easily Removable Cover With Ample Area For Maintenance. The Cam Shaft Is Mounted On Bearing Bushes On Walls Of Housing. The Cam Are Made Of Thermoplast Material And Fixed On Square Spindle Switch Which Is Moved By A Handle. The Cams Are Cut To Correspond To The Switching Program Aluminium Die Cast Powder Coated Suitable For Hoist-Grab, Mill Duty, E. O. T. Cranes And Rolling Mill Drives.



Sheet Steel Enclosure (IP 41)

Dimension Details					
Type	L	D	No. Of Contacts	No. Of Cable Entries	
				Dia 20	Dia 26
1	135	105	8	2	2
2	195	165	12	2	4
3	245	215	18	2	4
4	305	265	24	2	6

Body Material	Aluminium Die Cast
Protection Degree	IP - 41 (IS/IEC-60529(2001))
Mounting Position	Horizontal
Contact Material	Silver Cadmium
Rated Voltage	500 V. A. C.
Thermal Test Current	10 Amps.
Cable Entries	2 X 20, 2 x 26 standard conduct
Input Speed	1200 RPM, Maximum
Contacts	Single break
No. of Contacts	24 maximum
No. of Steps	6-0-6 maximum
Optional	Spring return /Deadman's handle arrangment

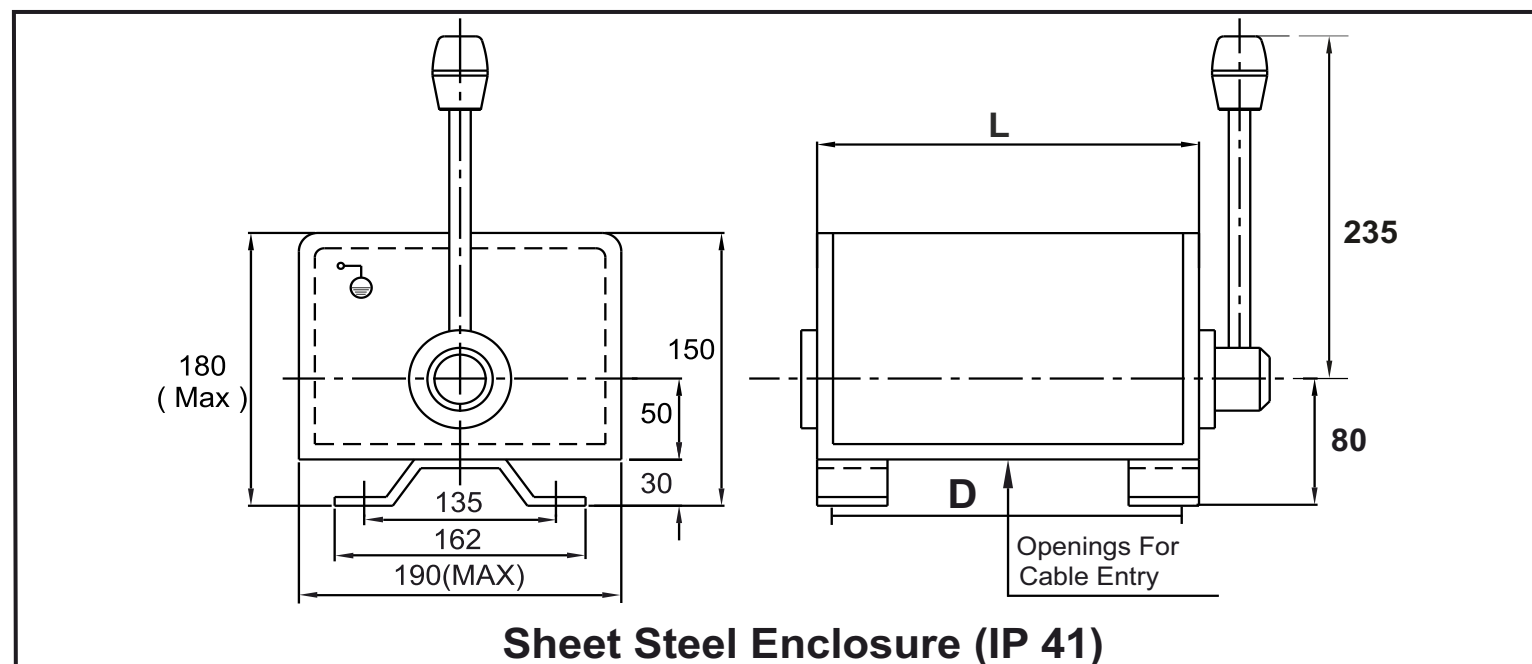

Sheet Steel Enclosure (IP 41)



Multitech Systems

Plot No. 48-49, Gali No.6, Krishna Colony, Opp. Sector-25, Faridabad-121004, Haryana
 E-mail : mtscranes@gmail.com | sales@multitechsystems.in
www.multitechsystem.net, 9910705767, 9911723747



9911417747
 9560063747
 9910043747
 9911283747

Master Controller(IP-54)

INTRODUCTION

Master Controller Is Housed In Enclosure And Provided With An Easily Removable Cover With Ample Area For Maintenance. The Cam Shaft Is Mounted On Bearing Bushes On Walls Of Housing. The Cam Are Made Of Thermoplast Material And Fixed On Square Spindle Switch Which Is Moved By A Handle. The Cams Are Cut To Correspond To The Switching Program Aluminium Die Cast Powder Coated Suitable For Hoist-Grab, Mill Duty, E. O. T. Cranes And Rolling Mill Drives.



Technical Data :

Body Material	Aluminium Die Cast
Protection Degree	IP - 54 (IS/IEC-60529(2001))
Mounting Position	Horizontal
Contact Material	Silver Cadmium
Rated Voltage	500 V. A. C.
Thermal Test Current	40 Amps.
Cable Entries	2 X 20, 2 x 26 standard conduct
Input Speed	1200 RPM, Maximum
Contacts	Single break
No. of Contacts	24 maximum
No. of Steps	6-0-6 maximum
Optional	spring return /deadman's handle arrangment

Aluminum Die Cast

Dimension Details						
Type	A	B	C	No. Of Contacts	No. Of Cable Entries	
					Dia 20	Dia 25
Small	170	220	150	8	1	1
Medium	267	317	245	16	2	2
Big	370	420	140	24	2	2

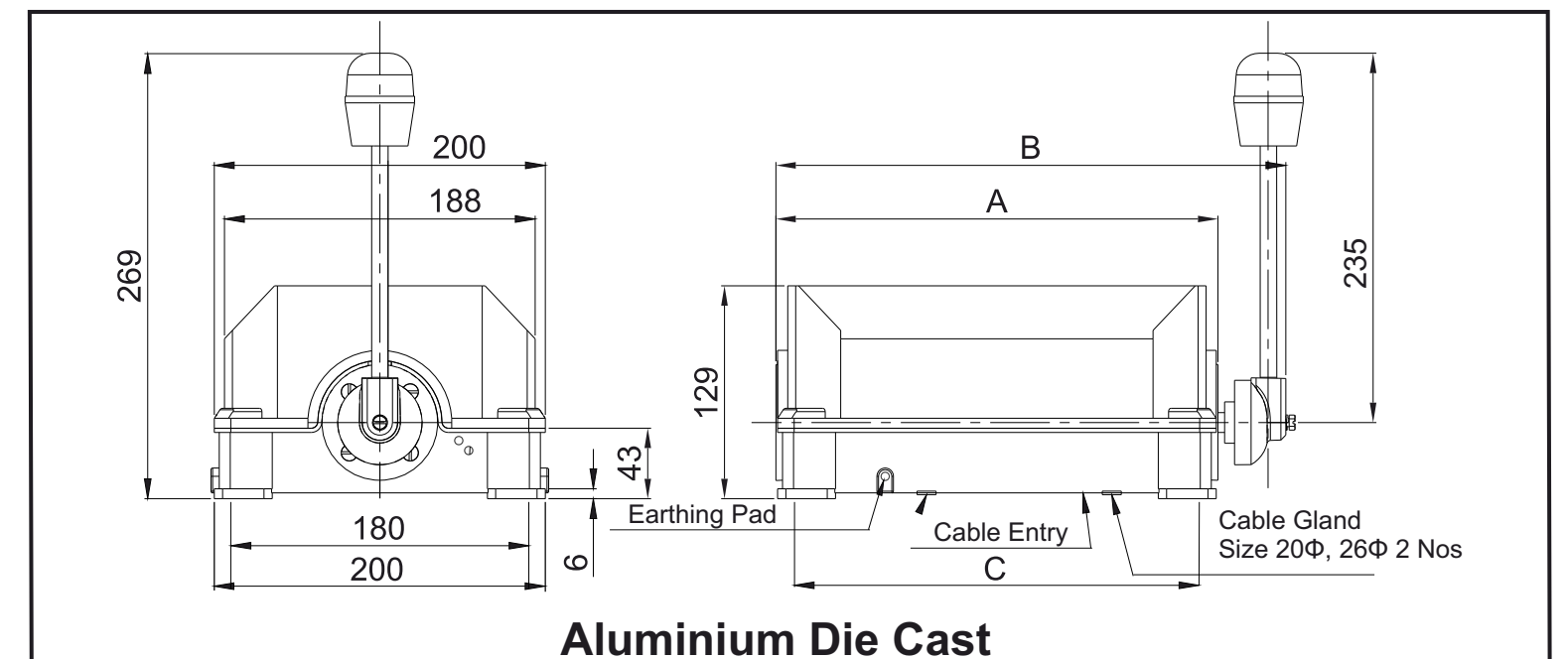

Aluminium Die Cast



Multitech Systems

Plot No. 48-49, Gali No.6, Krishna Colony, Opp. Sector-25, Faridabad-121004, Haryana
 E-mail : mtscranes@gmail.com | sales@multitechsystems.in
www.multitechsystem.net, 9910705767, 9911723747



9911417747
 9560063747
 9910043747
 9911283747

Punched Grid Resistance Box - PS

INTRODUCTION

Resistance Boxes Are Used To Add Resistance Into An Electric Motor Circuit For Modifying The Performance Characteristic Of Slipping Induction Motor Of Eot Cranes, Rubber Mills, Steel Rolling Mills, Cement Mills, Power Plants, Conveyors, Coke Oven, Blowers Etc. For Speed Control And Developing Starting Torque With Low Starting Currents. They Are Also Used As Dynamic Braking For Vvfv Ac Drives, Electric Loading Of Ac Alternators, Degenerators And Dynamometers. Resistors Are Designed To Meet Requirements Of Both A.c & D.c. Applications.

Technical Data Dynamic Breaking Resistor

Type Of Grid	Punched Grid
Cooling	Natural Air cooled
Resistors Material	Stainless Steel / Fechral
Enclosure	Sheet Steel (Galvanized)
Mounting	Floor Mounting Horizontal
Cable Entry	Bottom
Protection Degree	IP-20 / IP-21 / IP-23 / IP-33.
Over Ambient Temperature	375° C
Current Rating	8 Amps -----3000 Amps
Connections	Series / Parallel
Voltage	600 V
Terminals	3/8"
Other Voltage	1100/3300 V on request

Resistance Boxes

Current rating chart for punched grid resistors for 375°C temperature rise

Grid Type	Rated value (Ohms)	Current rating for various duty factors (Amps)			
		25% ED	40 %ED	60%ED	100%ED
PS10	0.010	390	325	280	234
PS15	0.015	318	265	228	190
PS22	0.022	265	220	190	158
PS32	0.032	220	182	153	131
PS46	0.046	185	151	130	110
PS68	0.068	152	126	110	90
PS100	0.100	125	103	88	74
PS150	0.150	101	84	72	61
PS220	0.220	83	70	59	50
PS300	0.300	82	59	50	43
PS460	0.460	58	48	40	35
PS720	0.720	47	39	33	28
PS1000	1.000	40	33	28	24
PS1500	1.500	32	27	23	19
PS2500	2.500	25	21	18	15
PS4500	4.500	15	13	11	8

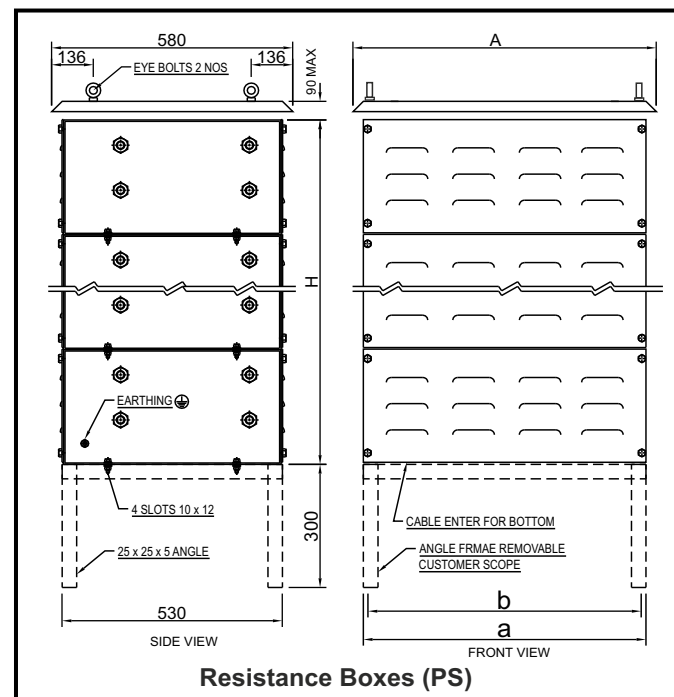

Resistance Boxes (PS)

Dimension Details of Punched Stainless Steel Resistance Boxes

Unit Size	A	a	b	Unit Size	A	a	b	H
A1	430	380	360	B1	580	530	510	280
A2	430	380	360	B2	580	530	510	560
C1	730	680	650	D1	880	830	805	280
C2	730	680	650	D2	880	830	805	560
C3	730	680	650	D3	880	830	805	840
C4	730	680	650	D4	880	830	805	1120
C5	730	680	650	D5	880	830	805	1400
C6	730	680	650	D6	880	830	805	1680

Dynamic Braking Resistor PS

INTRODUCTION

Braking Resistor are used in the D.C. Link of the frequency converter. A braking chopper activates the resistor. If the output frequency converter drops-be it by a control process, a drop in speed or a braking operation-below the current operating frequency of the motor, the motor takes on the function of a generator./ The consequence is arise in the link voltage. If this voltage exceeds the specific value of the unit in question, chopper the specific value of the unit in resistor. If the voltage drops to a value just above the grid voltage of the link, the chopper will interrupt the circuit. This process will be repeated until the motor speed once again matches the applied operating frequency. The braking resistor takes on the energy and converts it into heat.

Braking Resistor Operating Modes

Braking Resistor are usually only activated for a short time, save the braking energy and give off the short time, save the braking energy and give of the stored heat to the environment during the breaks when they are inactive. This intermittent operation with a cyclic duration factor (c.d.f) indicated in % of the duty cycle time. The duty cycle time TSP is calculated from the total of the braking time to plus resting timer. The overload capacity of the resistor is dependent on the thermal time constant and thus on the design, among others.

The Resistance Value Of The Braking Resistors

In general, the resistance value of a braking resistor is not critical, If may range between the lowest value of the admissible value for the braking chopper and a maximum value where the required braking performance is still achieved. Assuming a standard reserved of 25% which takes into account the manufacturing tolerance and the resistance change to heating up as well as the lower mean value of the link voltage as compared with the chopper activating voltage, the maximum value for the braking resistor is calculated as:

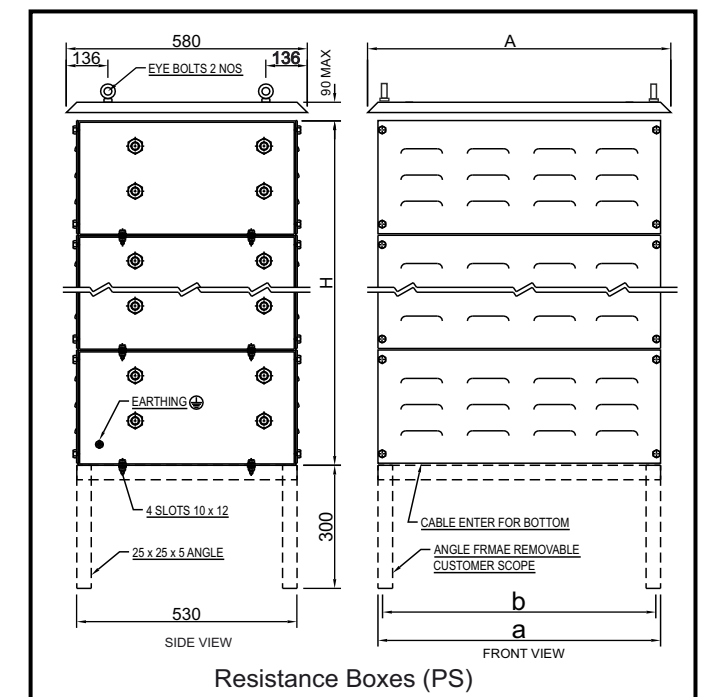

Resistance Boxes (PS)

Dimension Details of Punched Stainless Steel Resistance Boxes

Unit Size	A	a	b	Unit Size	A	a	b	H
A1	430	380	360	B1	580	530	510	280
A2	430	380	360	B2	580	530	510	560
C1	730	680	650	D1	880	830	805	280
C2	730	680	650	D2	880	830	805	560
C3	730	680	650	D3	880	830	805	840
C4	730	680	650	D4	880	830	805	1120
C5	730	680	650	D5	880	830	805	1400
C6	730	680	650	D6	880	830	805	1680



Multitech Systems

Plot No. 48-49, Gali No.6, Krishna Colony, Opp. Sector-25, Faridabad-121004, Haryana
E-mail : mtscranes@gmail.com | sales@multitechsystems.in
www.multitechsystem.net, 9910705767, 9911723747



9911417747
9560063747
9910043747
9911283747



Multitech Systems

Plot No. 48-49, Gali No.6, Krishna Colony, Opp. Sector-25, Faridabad-121004, Haryana
E-mail : mtscranes@gmail.com | sales@multitechsystems.in
www.multitechsystem.net, 9910705767, 9911723747



9911417747
9560063747
9910043747
9911283747

TELECRANE® RADIO REMOTE CONTROL

Model : F21-2S

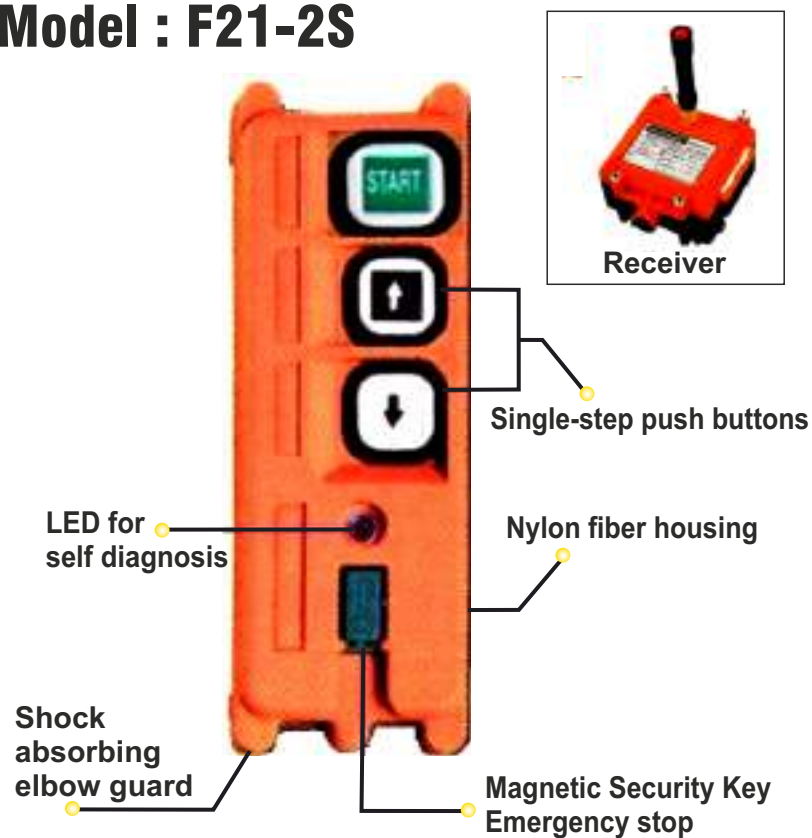

GENERAL

- Encoding : Microprocessor based
- Decoding : Microprocessor based
- Range : 100M Approx.
- Temperature : -35°C - +80°C

TRANSMITTER

- 2 Single-step Buttons, 1 Start Button
- Powered by size AA x 2 Alkaline or rechargeable battery.
- Size : 130 x 45 x 22 mm
- Power Supply : 3V
- Weight : About 120 g
- Housing : Nylon Fiber

RECEIVER

- Power Supply : 110/220VAC 50 Hz
- Size : 84 x 82 x 48 mm
- Housing : Nylon fiber
- Relay output : 10A/250V
- Antenna : External
- Weight : About 550 g

TELECRANE® RADIO REMOTE CONTROL

Model : F21-2SB

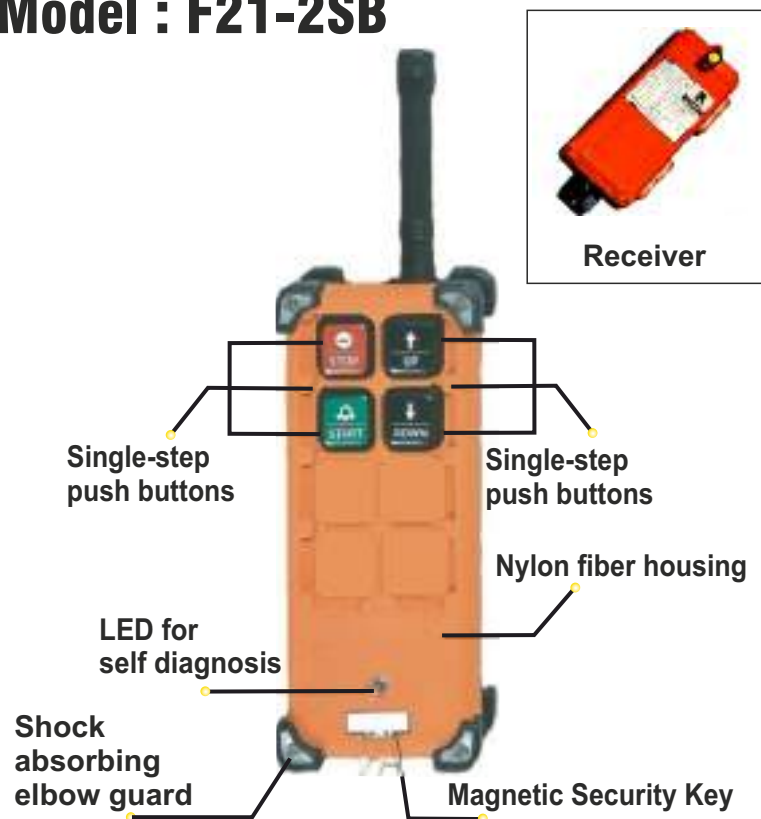

GENERAL

- Encoding : Microprocessor based
- Decoding : Microprocessor based
- Range : 100M Approx.
- Temperature : -35°C - +80°C-

TRANSMITTER

- 2 Single-step Buttons, 1 Emergency Stop, 1 Start Button
- Powered by size AA x 2 Alkaline or rechargeable battery.
- Proving 9 control contacts.
- Size : 164 x 75 x 46 mm (excluding protrusion)
- Power Supply : 3V
- Weight : About 350 gms
- Housing : Nylon Fiber

RECEIVER

- Power Supply : 110/220VAC 50 Hz
- Size : 185 x 85 x85 mm
- Housing : Nylon fiber
- Relay output : 10A/250V
- Antenna : External
- Weight : About 550 g

TELECRANE® RADIO REMOTE CONTROL

Model : F21-4SB

(PC Programmable)

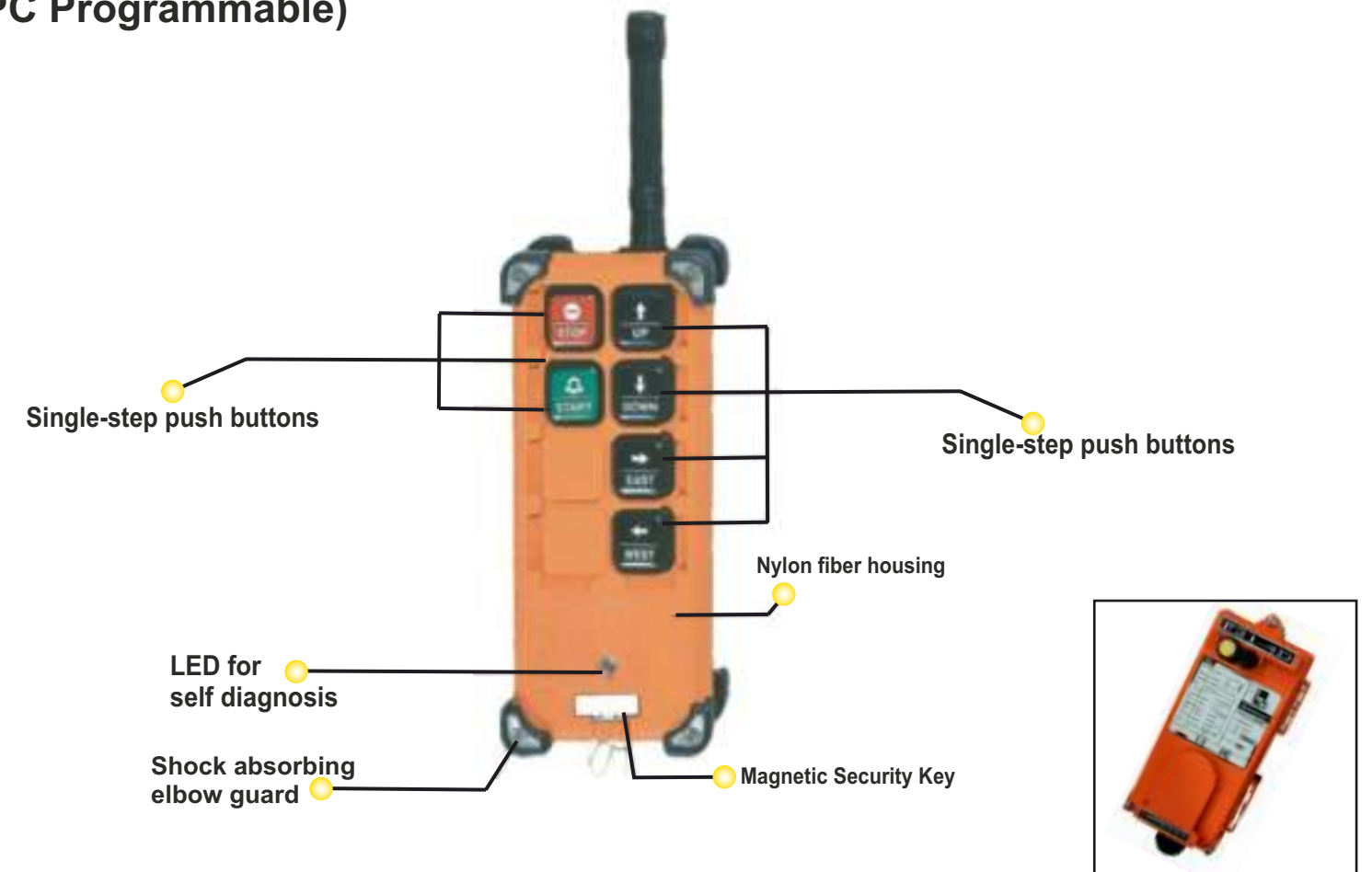

GENERAL

- Encoding : Microprocessor based
- Decoding : Microprocessor based
- Range : 100M Approx.
- Temperature : -30°C - +80°C-

TRANSMITTER

- 4 single-step buttons, 1 Emergency stop, 1 Start button
- Powered by size AA x 2 Alkaline or rechargeable battery.
- Proving 9 control contacts.
- Size : 164 x 75 x 46 mm (excluding protrusion)
- Power Supply : 3V
- Weight : About 350 gms
- Housing : Nylon Fiber

RECEIVER

- Power Supply : 110/220VAC 50Hz
- Size : 185 x 85 x85 mm
- Housing : Nylon fiber
- Relay output : 10A/250V
- Antenna : External
- Weight : About 550 g



Multitech Systems

Plot No. 48-49, Gali No.6, Krishna Colony, Opp. Sector-25, Faridabad-121004, Haryana
E-mail : mtscranes@gmail.com | sales@multitechsystems.in
www.multitechsystem.net, 9910705767, 9911723747



9911417747
9560063747
9910043747
9911283747



Multitech Systems

Plot No. 48-49, Gali No.6, Krishna Colony, Opp. Sector-25, Faridabad-121004, Haryana
E-mail : mtscranes@gmail.com | sales@multitechsystems.in
www.multitechsystem.net, 9910705767, 9911723747



9911417747
9560063747
9910043747
9911283747

TELECRANE® RADIO REMOTE CONTROL

Model : F21-E1B

(PC Programmable)

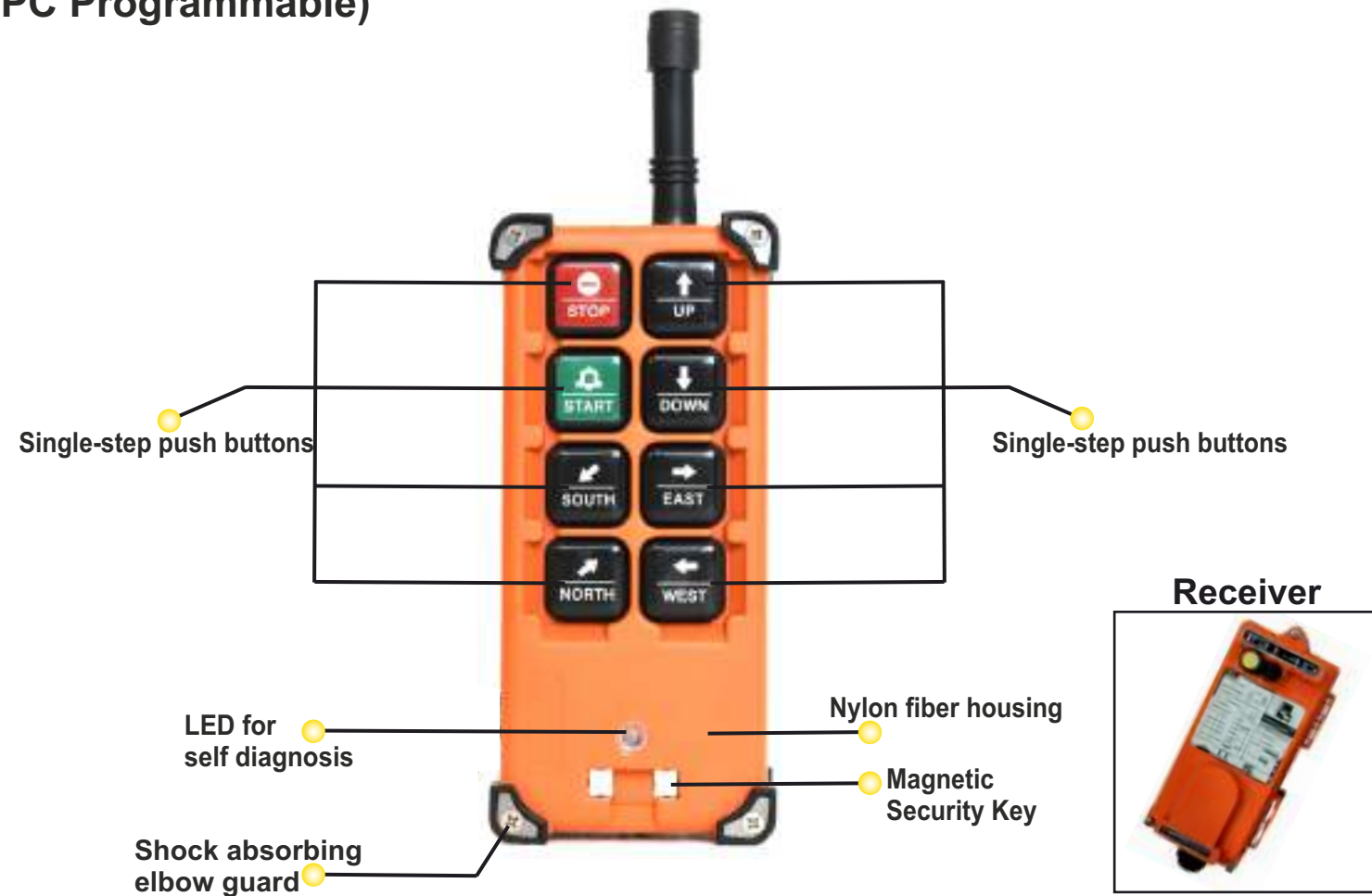

GENERAL

- Encoding : Microprocessor based
- Decoding : Microprocessor based
- Range : 100M Approx.
- Temperature : -30°C - +80°C-

TRANSMITTER

- 6 single-step buttons, 1 Emergency stop, 1 button
- Powered by size AA x 2 Alkaline or rechargeable battery.
- Proving 9 control contacts.
- Size : 164 x 75 x 46 mm (excluding protrusion)
- Power Supply : 3V
- Weight : About 350gms
- Housing : Nylon Fiber

RECEIVER

- Power Supply : 110/220VAC 50Hz
- Size : 185 x 85 x85 mm
- Housing : Nylon fiber
- Relay output : 10A/250V
- Antenna : External
- Weight : About 550 g

TELECRANE® RADIO REMOTE CONTROL

Model : F24-BB

(PC Programmable)

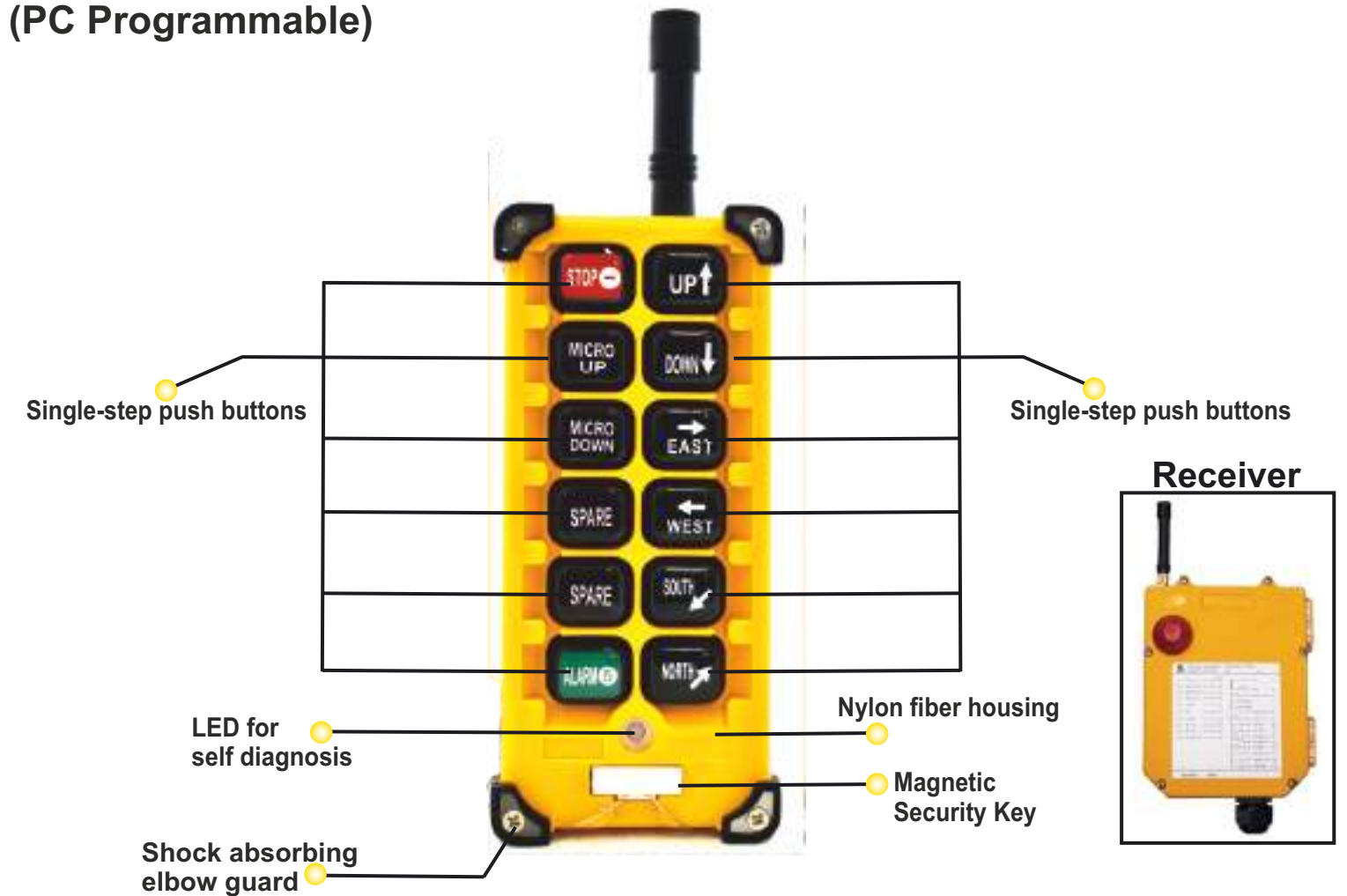

GENERAL

- Encoding : Microprocessor based
- Decoding : Microprocessor based
- Range : 100M Approx.
- Temperature : -30°C - +80°C

TRANSMITTER

- 10single-step buttons, 1 Emergency stop, 1 Start button
- Powered by size AA x 2 Alkaline battery.
- Size : 186 x61 x 51 mm (excluding protrusion)
- Power Supply : 3V
- Weight : about 260gms
- Housing : Nylon Fiber

RECEIVER

- Power Supply : 110/220VAC 50Hz
- Size : 200 x 162x 51 mm
- Housing : Nylon Fiber
- Weight : about 1225 gms



Multitech Systems

Plot No. 48-49, Gali No.6, Krishna Colony, Opp. Sector-25, Faridabad-121004, Haryana
E-mail : mtscranes@gmail.com | sales@multitechsystems.in
www.multitechsystem.net, 9910705767, 9911723747



9911417747
9560063747
9910043747
9911283747



Multitech Systems

Plot No. 48-49, Gali No.6, Krishna Colony, Opp. Sector-25, Faridabad-121004, Haryana
E-mail : mtscranes@gmail.com | sales@multitechsystems.in
www.multitechsystem.net, 9910705767, 9911723747



9911417747
9560063747
9910043747
9911283747

TELECRANE® RADIO REMOTE CONTROL

Model : F24-6D
(PC Programmable)

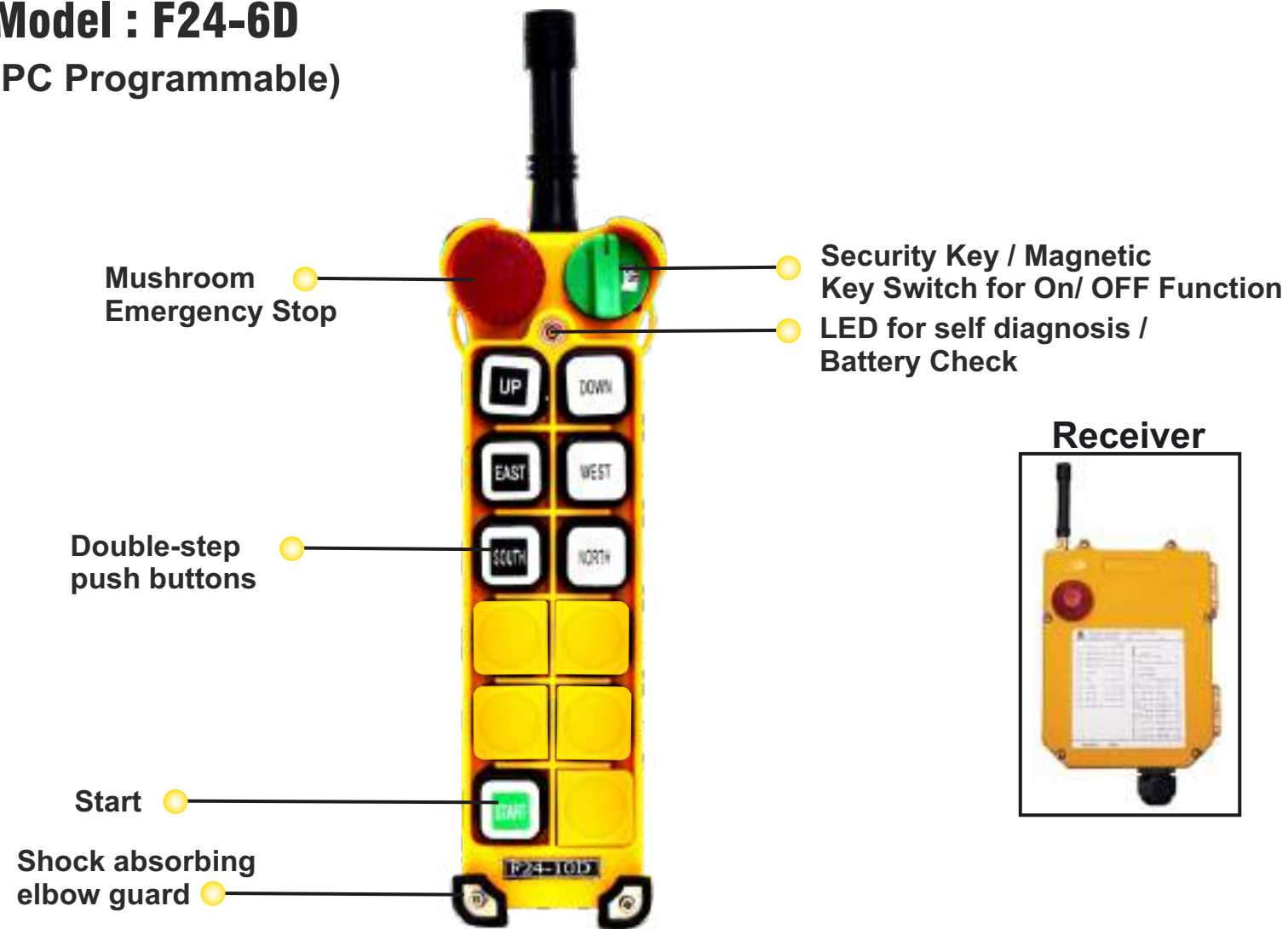

TELECRANE® RADIO REMOTE CONTROL

Model : F24-10D
(PC Programmable)

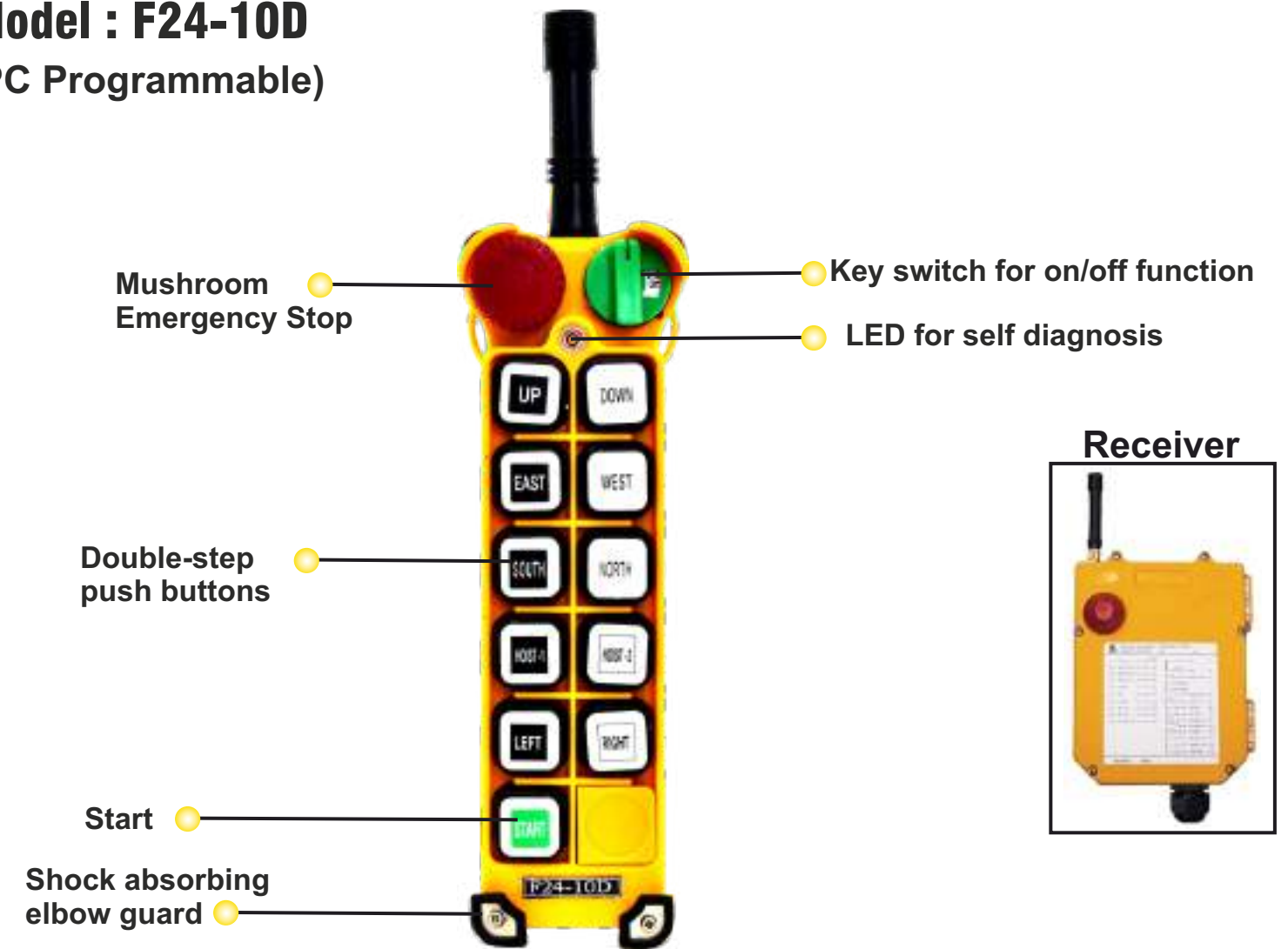

GENERAL

- Encoding : Microprocessor based
- Decoding : Microprocessor based
- Range : 100M Approx.
- Temperature : -30°C - +75°C-

TRANSMITTER

- 6 Double-step buttons, 1 Emergency stop, 1 Rotary key switch, 1 Start button
- Powered by size AA x 2 Alkaline battery.
- Size : 186 x61 x 51 mm (excluding protrusion)
- Power Supply : 3VDC
- Weight : About 260gms
- Housing : Nylon Fiber

RECEIVER

- Power Supply : 110/220VAC 50Hz
- Size : 200 x 162x 51 mm
- Housing : Nylon Fiber
- Weight : About 1225 gms

GENERAL

- Encoding : Microprocessor based
- Decoding : Microprocessor based
- Range : 100M Approx.
- Temperature : -30°C - +75°C-

TRANSMITTER

- 10 Single-step Buttons, 1 Emergency Stop, 1 Rotary key switch, 1 Start button
- Powered by size AA x 2 Alkaline battery.
- Size : 186 x61 x 51 mm (excluding protrusion)
- Power Supply : 3VDC
- Weight : About 260gms
- Housing : Nylon Fiber

RECEIVER

- Power Supply : 110/220VAC 50Hz
- Size : 200 x 162x 51 mm
- Housing : Nylon Fiber
- Weight : About 1225 gms



Multitech Systems

Plot No. 48-49, Gali No.6, Krishna Colony, Opp. Sector-25, Faridabad-121004, Haryana
E-mail : mtscranes@gmail.com | sales@multitechsystems.in
www.multitechsystem.net, 9910705767, 9911723747



9911417747
9560063747
9910043747
9911283747



Multitech Systems

Plot No. 48-49, Gali No.6, Krishna Colony, Opp. Sector-25, Faridabad-121004, Haryana
E-mail : mtscranes@gmail.com | sales@multitechsystems.in
www.multitechsystem.net, 9910705767, 9911723747



9911417747
9560063747
9910043747
9911283747

TELECRANE® RADIO REMOTE CONTROL

Model : F24-12D

(PC Programmable)

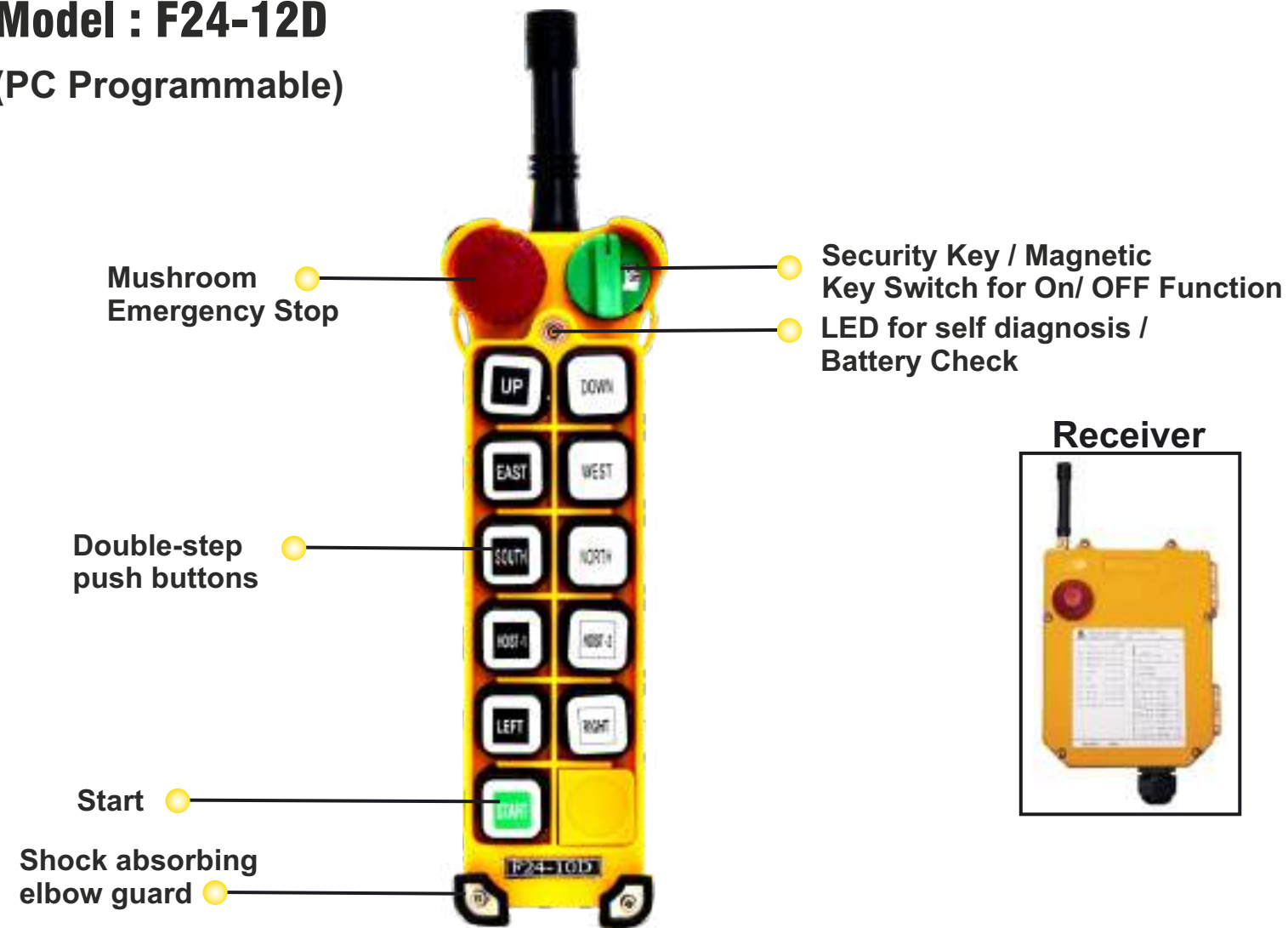

GENERAL

- Encoding : Microprocessor based
- Decoding : Microprocessor based
- Range : 100M Approx.
- Temperature : -35°C - +80°C

TRANSMITTER

- 6 single-step buttons, 1 Emergency stop, 1 Start button
- Powered by size AA x 2 Alkaline or rechargeable battery.
- Size : 164 x 75 x 46 mm (excluding protrusion)
- Power Supply : 3V
- Weight : about 350g
- Housing : Nylon Fiber

RECEIVER

- Power Supply : 110/220VAC 50Hz
- Size : 185 x 85 x 85 mm
- Housing : Nylon Fiber
- Power Supply : 110/220VAC 50Hz
- Size : External
- Housing : About 550g

TELECRANE® RADIO REMOTE CONTROL

Model : F24-60

(PC Programmable)

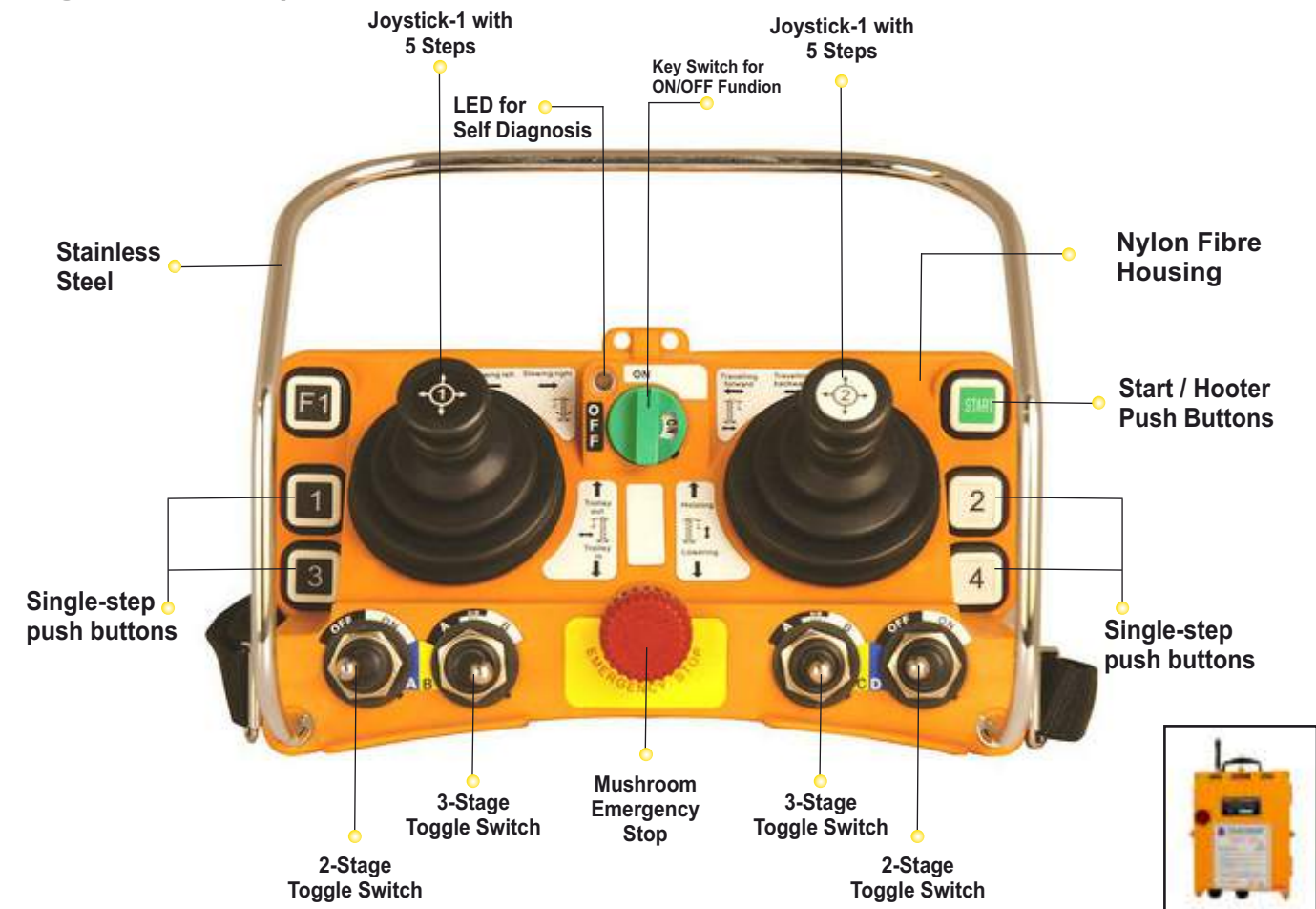

GENERAL

- Encoding : Microprocessor based
- Decoding : Microprocessor based
- Range : 100M Approx.
- Temperature : -30°C - +80°C

TRANSMITTER

- 10 single-step buttons, 1 Emergency stop, 1 Start button
- Powered by size AA x 2 Alkaline battery.
- Size : 186 x 61 x 51 mm (excluding protrusion)
- Power Supply : 3V
- Weight : about 260gms
- Housing : Nylon Fiber

RECEIVER

- Power Supply : 110/220VAC 50Hz
- Size : 290 x 230 x 70 mm
- Housing : Nylon Fiber
- Power Supply : 110A/25V
- Housing : Nylon Fiber
- Weight : About 1225 gms



Multitech Systems

Plot No. 48-49, Gali No.6, Krishna Colony, Opp. Sector-25, Faridabad-121004, Haryana
 E-mail : mtscranes@gmail.com | sales@multitechsystems.in
www.multitechsystem.net, 9910705767, 9911723747



9911417747
 9560063747
 9910043747
 9911283747



Multitech Systems

Plot No. 48-49, Gali No.6, Krishna Colony, Opp. Sector-25, Faridabad-121004, Haryana
 E-mail : mtscranes@gmail.com | sales@multitechsystems.in
www.multitechsystem.net, 9910705767, 9911723747



9911417747
 9560063747
 9910043747
 9911283747

SV-3S / 3D Push Buttons Pendant

2 + 1 - Single Speed / Two Speed
Description : 2 Push Button with 1 NO / (1 NO + 1 NO)
Progressive Contacts
+ 1 Emergency Stop with 1 NC Contact

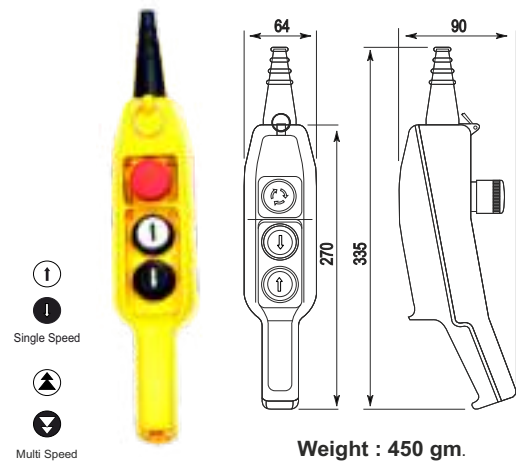

SV / 3 S



Weight : 450 gm.

SV-5S Push Buttons Pendant

4 + 1 - Single Speed
Description : 4 Push Button with 1 NO Contact
+ 1 Emergency Stop with 1 NC Contact

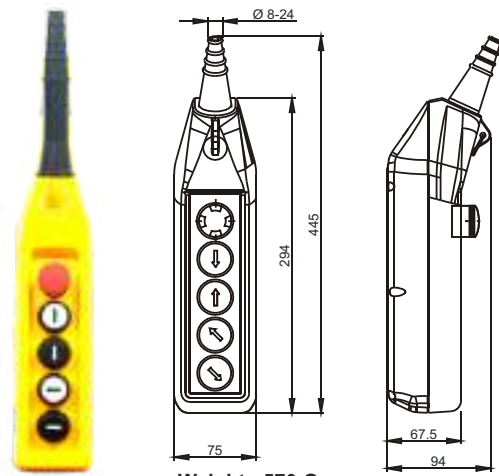

SV / 5 S



Weight : 570 Gm.

SH-6S / 6D Push Buttons Pendant

2 + 2 - Single Speed
Description : 4 Push Button with 1 NO Contacts
+ 1 Emergency Stop with 1 NC Contact
+ Start / Alarm with 2 No Contacts

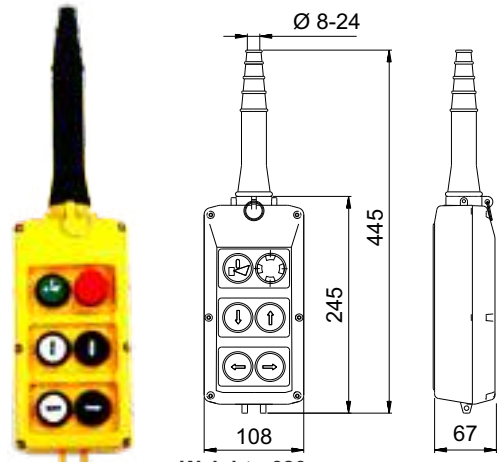

SH / 6S



Weight : 680 gm.

SV-7S / 7D Push Buttons Pendant

Description : 6 Push Button with 1 NO / 2 NO Contacts
+ 1 Emergency Stop with 1 NC Contact

SV / 7S

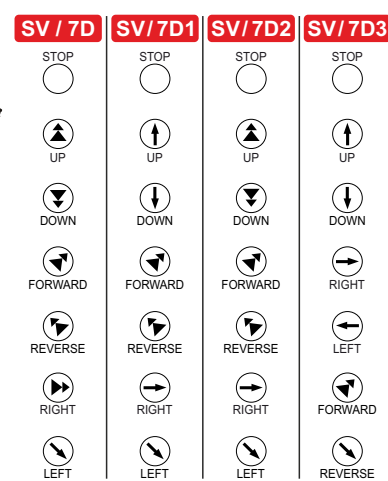
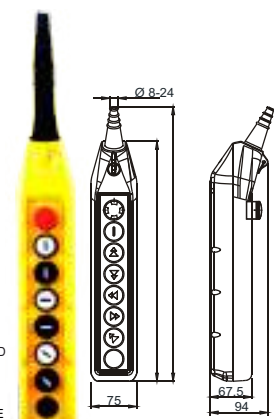

Weight : 830 Gm.

SV-8S & 8D Push Buttons Pendant

6 + 2 - Single / Double Speed
Description : 6 Push Button with 1 NO / 2 NO Contacts
+ 1 Emergency Stop with 1 NC Contact
+ 1 Start / Alarm with 2 NO Contact

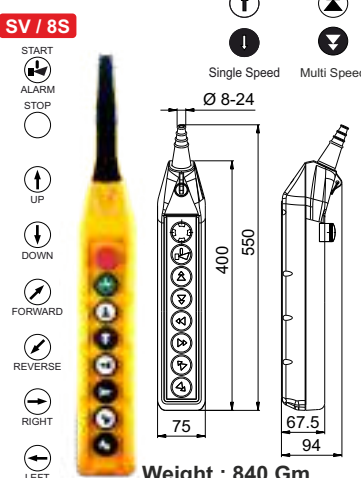

SV / 8S

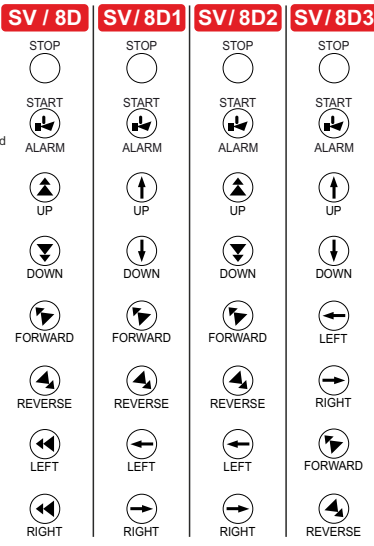
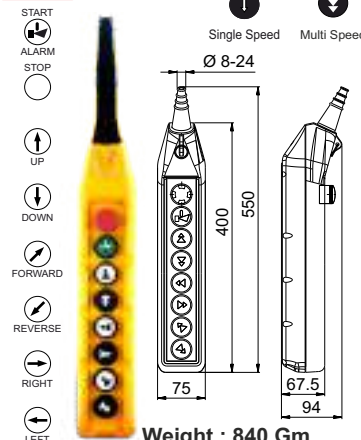

Weight : 840 Gm.

SH-8S / 8D Push Buttons Pendant

6 + 2 - Two Speed
Description : 6 Push Button with (1NO) / (1NO+1NO)
Progressive Contacts
+ 1 Emergency Stop with 1 NC Contact
+ Start / Alarm with 2 No Contacts

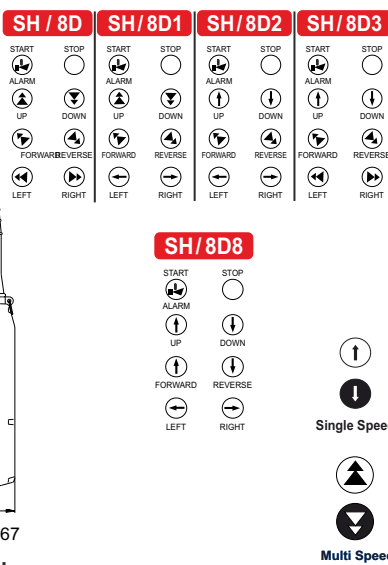

Weight : 1040 gm.

SH-10S / 10D Push Button Pendant

10 + 2 - Two Speed
Description : 8 Push Button with (1NO+1NO)
Progressive Contacts
+ 1 Emergency Stop with 1 NC Contact
+ Start / Alarm with 2 NO Contact

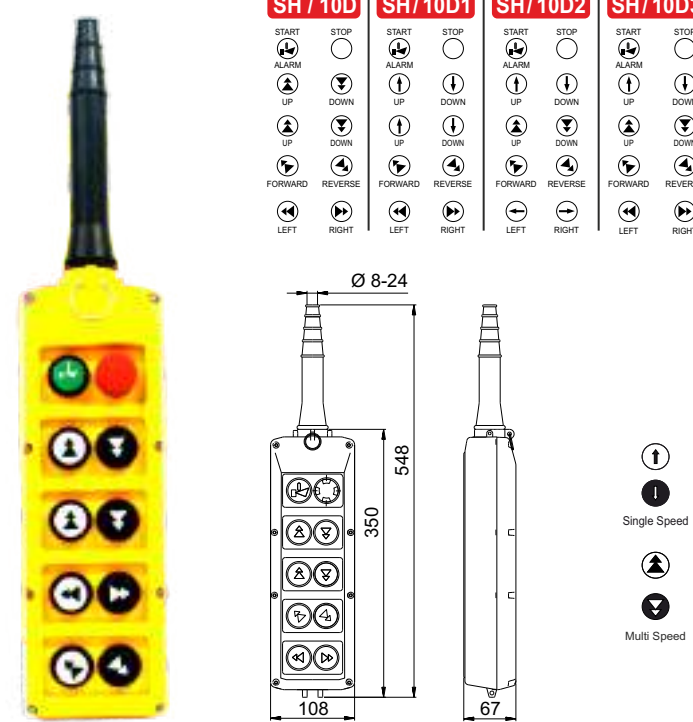

Weight : 1090 gm.

SV-10S / 10D Push Button Pendant

8 + 2 - Two Speed
Description : 8 Push Button with (1NO+1NO)
Progressive Contacts
+ 1 Emergency Stop with 1 NC Contact
+ Start / Alarm with 2 NO Contact

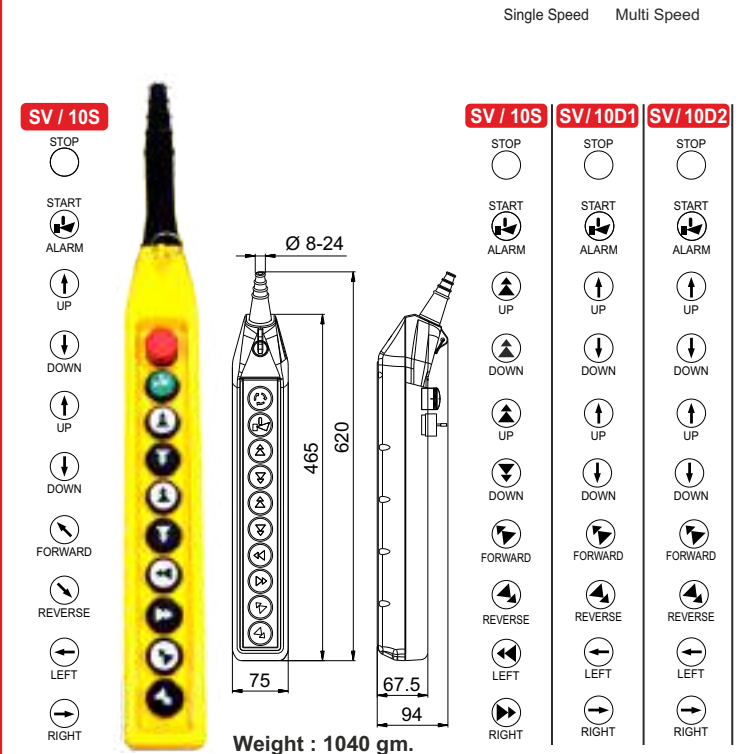

Weight : 1040 gm.

SV-12S Push Button Pendant

10 + 2 - Single Speed
Description : 10 Push Button with 1 NO Contact
+ 1 Emergency Stop with 1 NC Contact
+ 1 Start / Alarm with 2 NO Contact

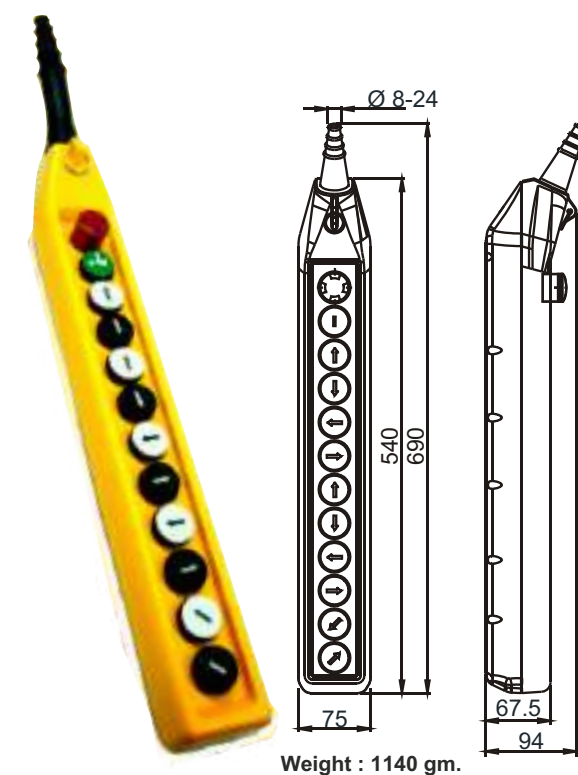

Weight : 1140 gm.

SV-12D Push Button Pendant

SV / 12D Push Buttons : 10 + 2 - Single / Double Speed
Description : 10 Push Button with (1NO) / (1NO+1NO) Contact
+ 1 Emergency Stop with 1 NC Contact
+ 1 Start / Alarm with 2 NO Contact

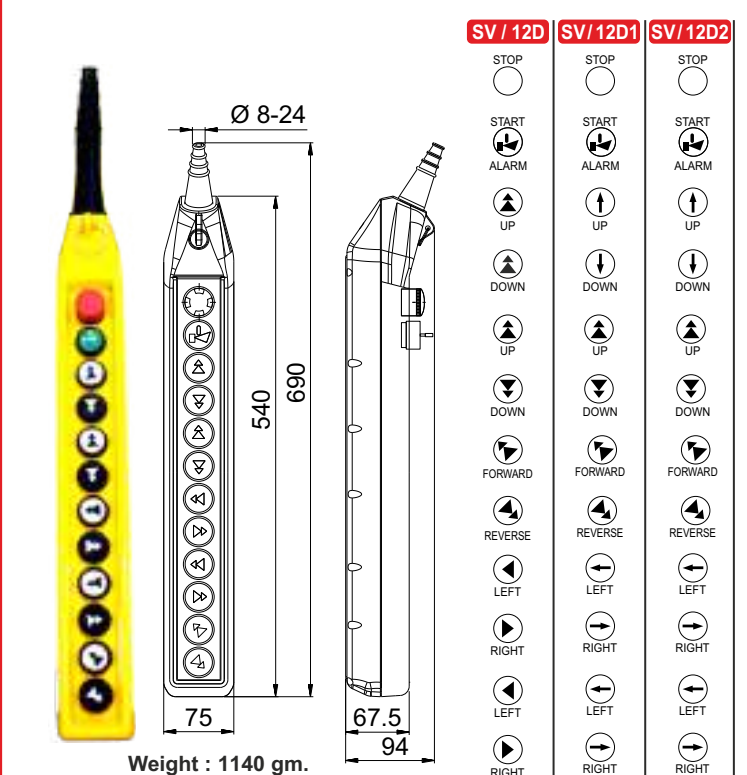

Weight : 1140 gm.



Multitech Systems

Plot No. 48-49, Gali No.6, Krishna Colony, Opp.
Sector-25, Faridabad-121004, Haryana
E-mail : mtscranes@gmail.com | sales@multitechsystems.in
www.multitechsystem.net, 9910705767, 9911723747



9911417747
9560063747
9910043747
9911283747



Multitech Systems

Plot No. 48-49, Gali No.6, Krishna Colony, Opp.
Sector-25, Faridabad-121004, Haryana
E-mail : mtscranes@gmail.com | sales@multitechsystems.in
www.multitechsystem.net, 9910705767, 9911723747



9911417747
9560063747
9910043747
9911283747

SH-12S Push Button Pendant

10 + 2 - Single Speed
Description : 10 Push Button with 1 NO Contact
+ 1 Emergency Stop with 1 NC Contact
+ 1 Start / Alarm with 2 NO Contact

SH/12S

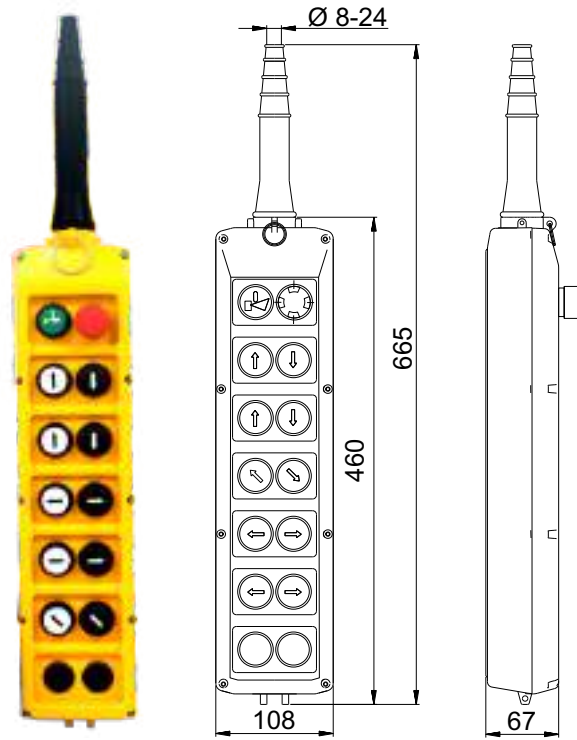

Weight : 1280 gm.



SH-12D Push Button Pendant

10 + 2 - Two Speed
Description : 10 Push Button with (1 NO + 1 NO)
Progressive Contacts
+ 1 Emergency Stop with 1 NC Contact
+ 1 Start / Alarm with 2 NO Contact

SH/12D SH/12D1 SH/12D2 SH/12D3

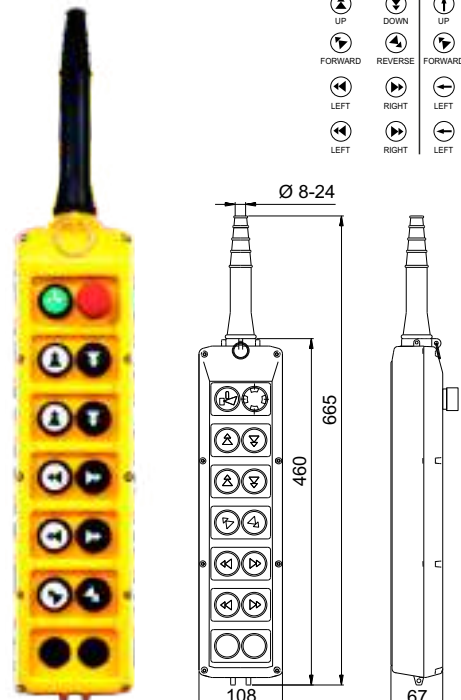
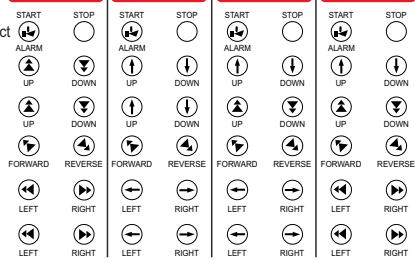

Weight : 1390 gm.



SH-14S Push Button Pendant

12 + 2 - Single Speed
Description : 1 Push Button with 1 NO Contact
+ 1 Emergency Stop with 1 NC Contact
+ 1 Start / Alarm with 2 NO Contact

SH/14S

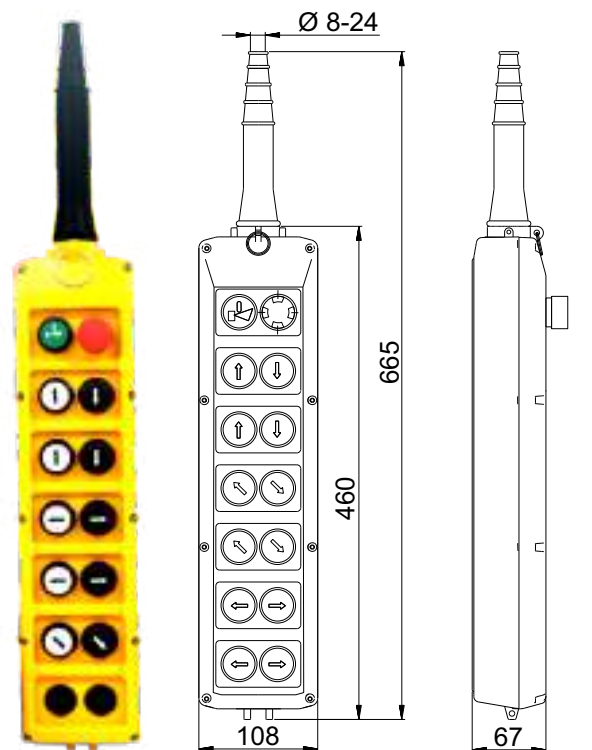

Weight : 1280 gm.



SH-14D Push Button Pendant

12 + 2 - Two Speed
Description : 12 Push Button with (1 NO + 1 NO)
Progressive Contacts
+ 1 Emergency Stop with 1 NC Contact
+ 1 Start / Alarm with 2 NO Contact

SH/14D SH/14D1 SH/14D2 SH/14D3

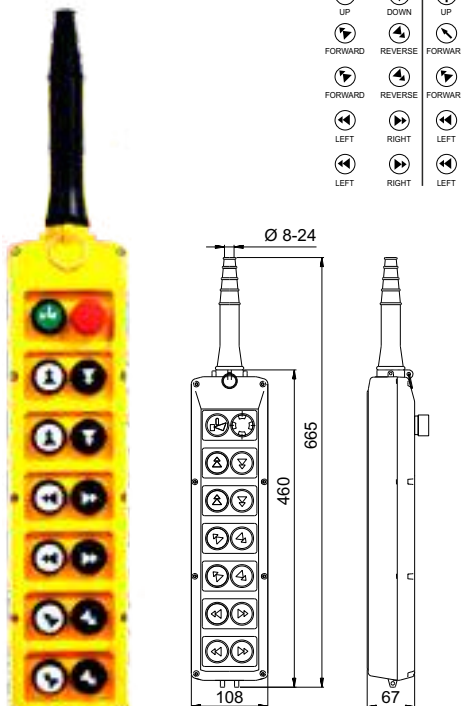
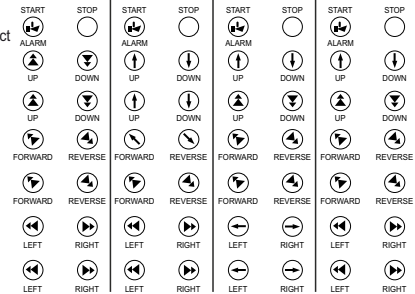

Weight : 1390 gm.

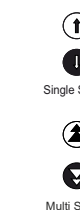

AC SOLENOIDS BRAKES

Technical Specification

Model	EMD - 4	EMD - 5.5	EMD - 7
Item Code			
Drum Dia (mm)	4" (101.6mm)	5.5" (139.7mm)	7" (177.8mm)
Breaking Torque (Kgm)	1.36	4.8	10.2
Stroke (mm)	25	31.4	31.4
Voltage Input	415	415	415
Holding Voltage	415	415	415
Operating Temperature	Ambient Temp.	Ambient Temp.	Ambient Temp.
Coil	CLASS F Insulation	CLASS F Insulation	CLASS F Insulation
Rating	Intermittent	Intermittent	Intermittent
No of Operations	720 Operations/Hr	720 Operations/Hr	720 Operations/Hr
Total Weight (kg)	5.5 Kg	11.5 Kg	15.5 Kg



Dimensions (mm)

BRAKE SIZE	TORQUE RAING N.m.	TORQUE RAING N.m.	A	B	C	D	E	F	G	H	J	K	P	Q	R
4.0"	13.6	1.3	102	73	178	67	32	140	78	10	16	73	79	76	79
5.5"	48	4.8	140	102	240	89	32	213	105	11	25	124	79	95	79
7.0"	102	10.2	178	127	291	111	64	241	127	14	25	124	79	121	79

G.A. Drawing

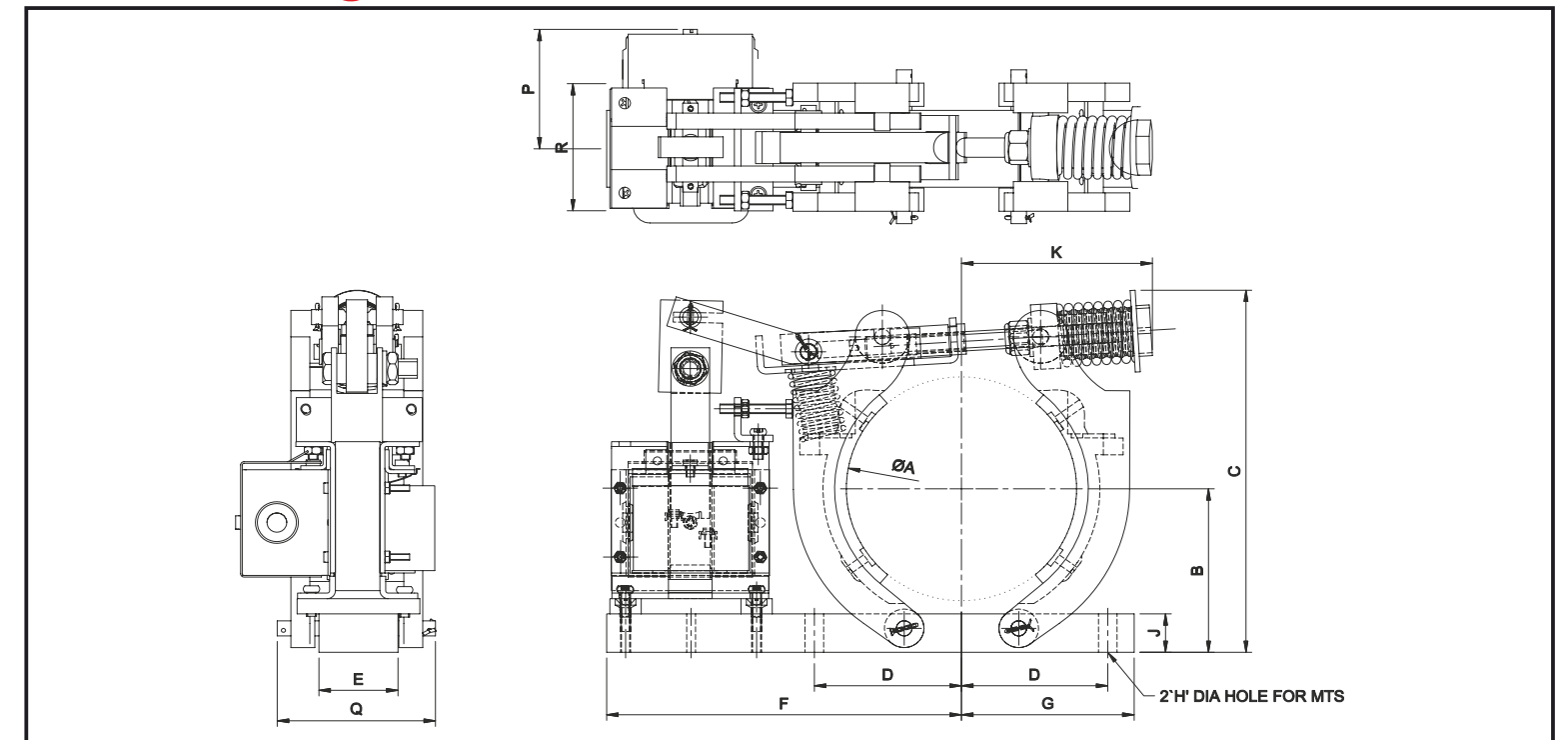

Multitech Systems

Plot No. 48-49, Gali No.6, Krishna Colony, Opp. Sector-25, Faridabad-121004, Haryana
E-mail : mtscranes@gmail.com | sales@multitechsystems.in
www.multitechsystem.net, 9910705767, 9911723747



9911417747
9560063747
9910043747
9911283747



Multitech Systems

Plot No. 48-49, Gali No.6, Krishna Colony, Opp. Sector-25, Faridabad-121004, Haryana
E-mail : mtscranes@gmail.com | sales@multitechsystems.in
www.multitechsystem.net, 9910705767, 9911723747



9911417747
9560063747
9910043747
9911283747

FESTOON / C RAIL SYSTEM

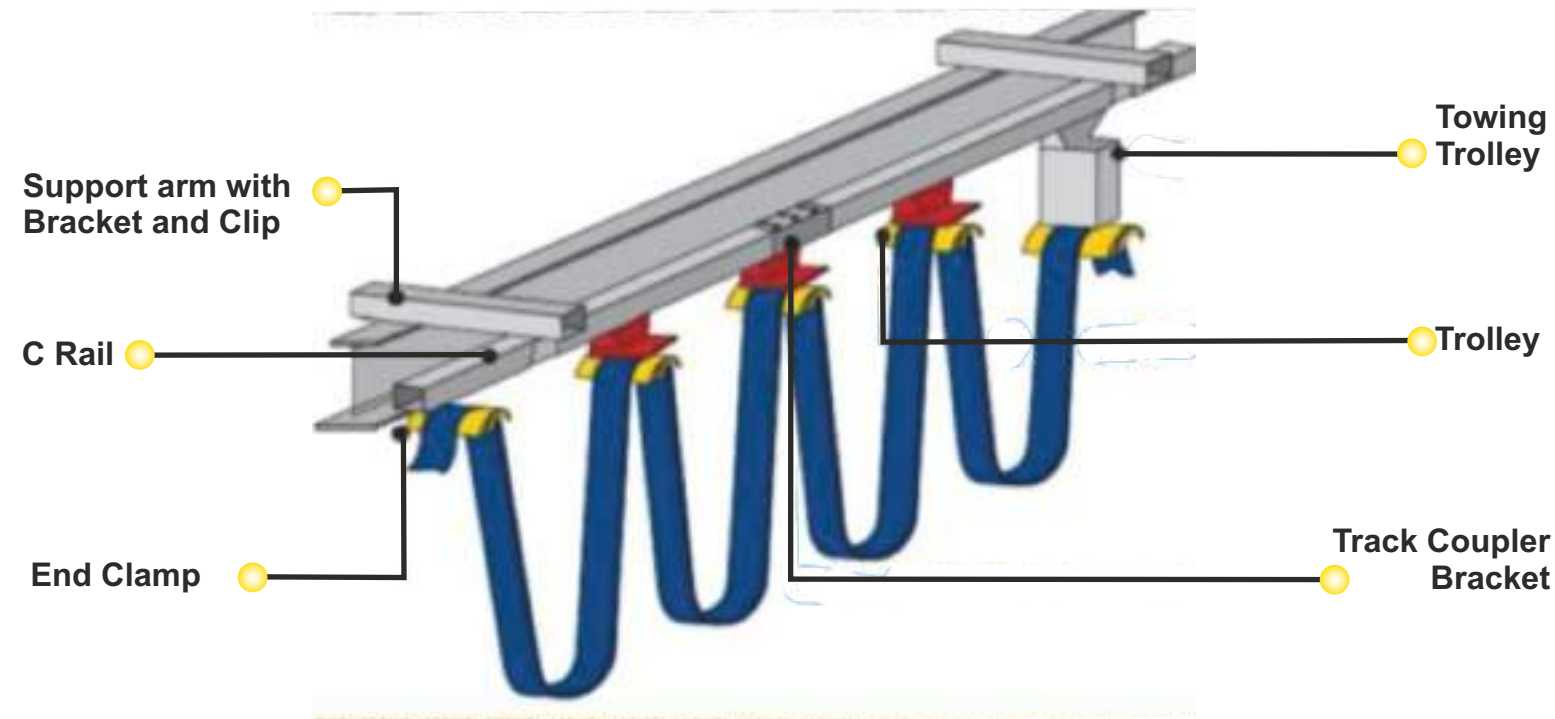

C - Rail



Tract Coupler

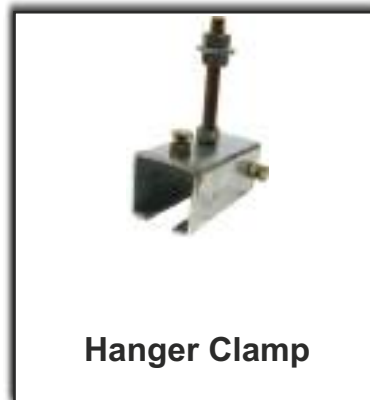

Hanger Clamp



End Clamp



Starting Trolley



BCT - Heavy Cable Trolley



BCT - Cable Trolley



BCT - Cable Trolley

LIMIT SWITCHES

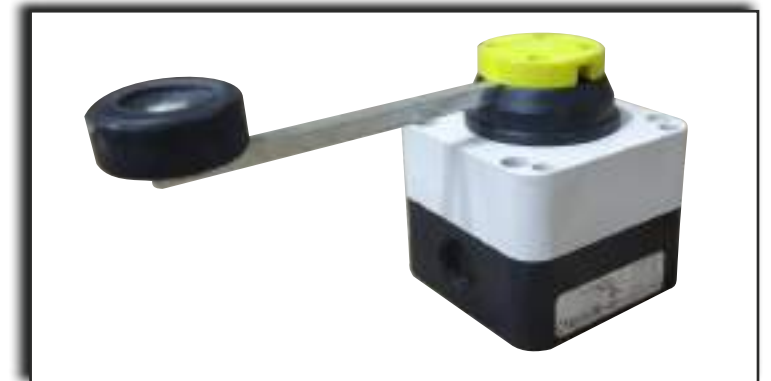
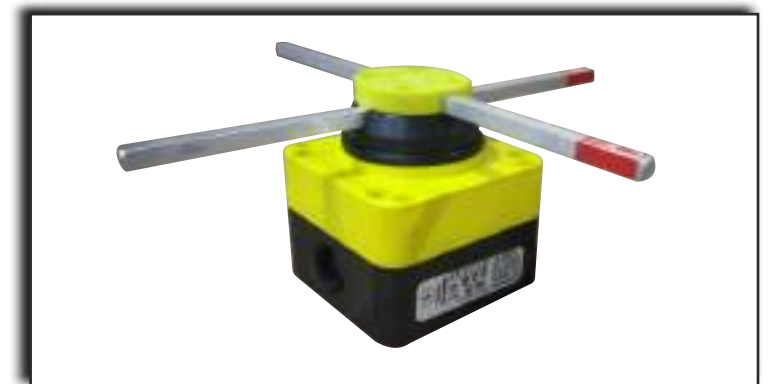

Cable Trolleys Four Wheel



Cable Trolley Medium Duty

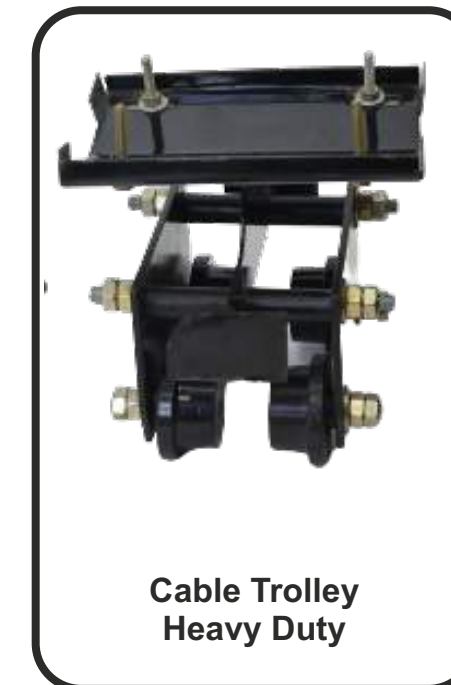

Cable Trolley Heavy Duty



Cable Trolley Double Decker



Multitech Systems

Plot No. 48-49, Gali No.6, Krishna Colony, Opp. Sector-25, Faridabad-121004, Haryana
 E-mail : mtscranes@gmail.com | sales@multitechsystems.in
www.multitechsystem.net, 9910705767, 9911723747



9911417747
 9560063747
 9910043747
 9911283747



Multitech Systems

Plot No. 48-49, Gali No.6, Krishna Colony, Opp. Sector-25, Faridabad-121004, Haryana
 E-mail : mtscranes@gmail.com | sales@multitechsystems.in
www.multitechsystem.net, 9910705767, 9911723747



9911417747
 9560063747
 9910043747
 9911283747